

# CD405xB CMOS Single 8-Channel Analog Multiplexer or Demultiplexer With Logic-Level Conversion

## 1 Features

- Wide range of digital and analog signal levels:
  - Digital: 3 V to 20 V
  - Analog:  $\leq 20 V_{P-P}$
- Low ON resistance, 125  $\Omega$  (typical) over 15  $V_{P-P}$  signal input range for  $V_{DD} - V_{EE} = 18 V$
- High OFF resistance, channel leakage of  $\pm 100 pA$  (typical) at  $V_{DD} - V_{EE} = 18 V$
- Logic-level conversion for digital addressing signals of 3 V to 20 V ( $V_{DD} - V_{SS} = 3 V$  to 20 V) to switch analog signals to 20  $V_{P-P}$  ( $V_{DD} - V_{EE} = 20 V$ ) matched switch characteristics,  $r_{ON} = 5 \Omega$  (typical) for  $V_{DD} - V_{EE} = 15 V$  very low quiescent power dissipation under all digital-control input and supply conditions, 0.2  $\mu W$  (typical) at  $V_{DD} - V_{SS} = V_{DD} - V_{EE} = 10 V$
- Binary address decoding on chip
- 5 V, 10 V, and 15 V parametric ratings
- 100% tested for quiescent current at 20 V
- Maximum input current of 1  $\mu A$  at 18 V over full package temperature range, 100 nA at 18 V and 25°C
- Break-before-make switching eliminates channel overlap

## 2 Applications

- Analog and digital multiplexing and demultiplexing
- Analog to digital and digital to analog conversion
- Signal gating
- Factory automation
- Televisions
- Appliances
- Consumer audio
- Programmable logic circuits
- Sensors

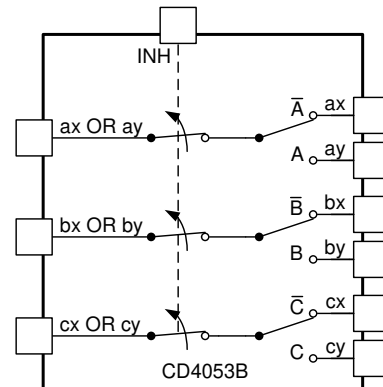
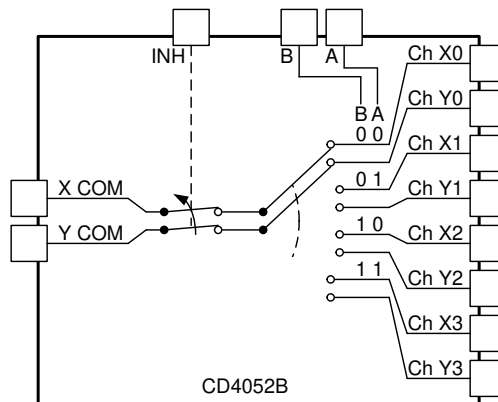
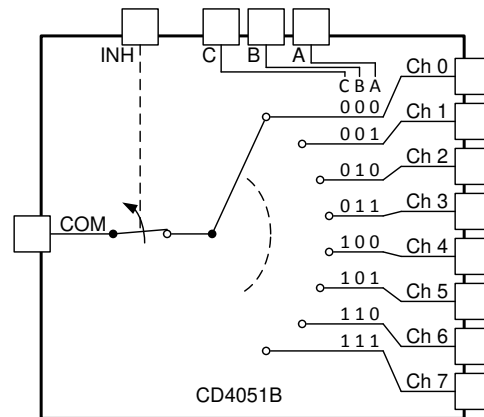
## 3 Description

The CD405xB analog multiplexers and demultiplexers are digitally-controlled analog switches having low ON impedance and very low OFF leakage current. These multiplexer circuits dissipate extremely low quiescent power over the full  $V_{DD} - V_{SS}$  and  $V_{DD} - V_{EE}$  supply-voltage ranges, independent of the logic state of the control signals.

### Package Information<sup>(1)</sup>

PART NUMBER	PACKAGE	BODY SIZE (NOM)
CD405xB	J (CDIP, 16)	19.50 mm × 6.92 mm
	N (PDIP, 16)	19.30 mm × 6.35 mm
	D (SOIC, 16)	9.90 mm × 3.91 mm
	NS (SOP, 16)	10.30 mm × 5.30 mm
	PW (TSSOP, 16)	5.00 mm × 4.40 mm

(1) For all available packages, see the orderable addendum at the end of the data sheet.



Functional Diagrams of CD405xB



## Table of Contents

<b>1 Features</b> .....	1	<b>8 Detailed Description</b> .....	20
<b>2 Applications</b> .....	1	8.1 Overview.....	20
<b>3 Description</b> .....	1	8.2 Functional Block Diagrams.....	21
<b>4 Revision History</b> .....	2	8.3 Feature Description.....	22
<b>5 Pin Configuration and Functions</b> .....	3	8.4 Device Functional Modes.....	23
<b>6 Specifications</b> .....	5	<b>9 Application and Implementation</b> .....	24
6.1 Absolute Maximum Ratings.....	5	9.1 Application Information.....	24
6.2 ESD Ratings.....	5	9.2 Typical Application.....	24
6.3 Recommended Operating Conditions.....	5	9.3 Power Supply Recommendations.....	25
6.4 Thermal Information.....	5	9.4 Layout.....	25
6.5 Electrical Characteristics – TSSOP Package.....	6	<b>10 Device and Documentation Support</b> .....	27
6.6 AC Performance Characteristics – TSSOP Package.....	10	10.1 Documentation Support.....	27
6.7 Electrical Characteristics – CDIP, PDIP, SOIC and SOP Packages.....	11	10.2 Receiving Notification of Documentation Updates.....	27
6.8 AC Performance Characteristics – CDIP, PDIP, SOIC and SOP Packages.....	15	10.3 Support Resources.....	27
6.9 Typical Characteristics.....	16	10.4 Trademarks.....	27
<b>7 Parameter Measurement Information</b> .....	16	10.5 Electrostatic Discharge Caution.....	27
		10.6 Glossary.....	27
		<b>11 Mechanical, Packaging, and Orderable Information</b> .....	27

## 4 Revision History

NOTE: Page numbers for previous revisions may differ from page numbers in the current version.

<b>Changes from Revision J (February 2023) to Revision K (March 2023)</b>	<b>Page</b>
• Added PW package information throughout the data sheet.....	1
<b>Changes from Revision I (September 2017) to Revision J (February 2023)</b>	<b>Page</b>
• Updated the numbering format for tables, figures, and cross-references throughout the document.....	1
• Updated the <i>Quiescent Device Current, IDD Max</i> typical and maximum values.....	5
• Updated the <i>OFF Channel Leakage Current: Any Channel OFF (Max) or ALL Channels OFF (Common OUT/IN) (Max)</i> typical values.....	5
• Updated the <i>ON Channel Leakage Current: Any Channel ON (Max) or ALL Channels ON (Common OUT/IN) (Max)</i> maximum values.....	5
• Updated the <i>Input Low Voltage, VIL, Max</i> values.....	5
• Updated the <i>Input Current, IIN (Max)</i> typical values.....	5
• Updated the <i>Inhibit-to-Signal OUT (Channel Turning OFF)</i> typical values.....	5
• Updated the values in the <i>ESD Ratings</i> section.....	5
• Updated the <i>Typical Characteristics</i> section.....	16
<b>Changes from Revision H (April 2015) to Revision I (September 2017)</b>	<b>Page</b>
• Added the <i>On Channel Leakage Current – Any Channel On</i> figure.....	16
<b>Changes from Revision G (October 2003) to Revision H (April 2015)</b>	<b>Page</b>
• Added <i>Pin Configuration and Functions</i> section, <i>ESD Ratings</i> table, <i>Feature Description</i> section, <i>Device Functional Modes</i> , <i>Application and Implementation</i> section, <i>Power Supply Recommendations</i> section, <i>Layout</i> section, <i>Device and Documentation Support</i> section, and <i>Mechanical, Packaging, and Orderable Information</i> section.....	1
• Added <i>Device Information</i> table.....	1

## 5 Pin Configuration and Functions

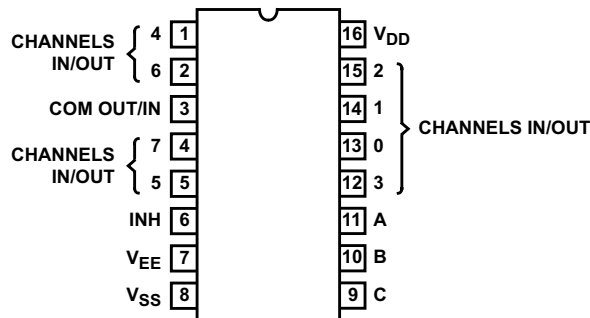


Figure 5-1. CD4051B E, M, NS, and PW Package, 16-Pin PDIP, CDIP, SOIC, SOP, and TSSOP (Top View)

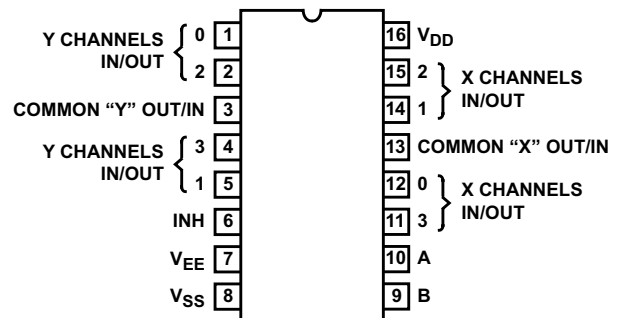


Figure 5-2. CD4052B E, M, NS, and PW Package, 16-Pin PDIP, CDIP, SOP, and TSSOP (Top View)

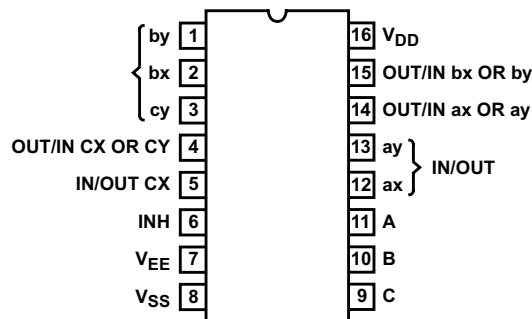


Figure 5-3. CD4053B E, M, NS, and PW Package, 16-Pin PDIP, CDIP, SOP, and TSSOP (Top View)

Table 5-1. Pin Functions CD4051B

PIN		TYPE <sup>(1)</sup>	DESCRIPTION
NO.	NAME		
1	CH 4 IN/OUT	I/O	Channel 4 in/out
2	CH 6 IN/OUT	I/O	Channel 6 in/out
3	COM OUT/IN	I/O	Common out/in
4	CH 7 IN/OUT	I/O	Channel 7 in/out
5	CH 5 IN/OUT	I/O	Channel 5 in/out
6	INH	I	Disables all channels. See <a href="#">Table 8-1</a> .
7	V <sub>EE</sub>	—	Negative power input
8	V <sub>SS</sub>	—	Ground
9	C	I	Channel select C. See <a href="#">Table 8-1</a> .
10	B	I	Channel select B. See <a href="#">Table 8-1</a> .
11	A	I	Channel select A. See <a href="#">Table 8-1</a> .
12	CH 3 IN/OUT	I/O	Channel 3 in/out
13	CH 0 IN/OUT	I/O	Channel 0 in/out
14	CH 1 IN/OUT	I/O	Channel 1 in/out
15	CH 2 IN/OUT	I/O	Channel 2 in/out
16	V <sub>DD</sub>	—	Positive power input

(1) I = input, O = output

**Table 5-2. Pin Functions CD4052B**

PIN		TYPE <sup>(1)</sup>	DESCRIPTION
NO.	NAME		
1	Y CH 0 IN/OUT	I/O	Channel Y0 in/out
2	Y CH 2 IN/OUT	I/O	Channel Y2 in/out
3	Y COM OUT/IN	I/O	Y common out/in
4	Y CH 3 IN/OUT	I/O	Channel Y3 in/out
5	Y CH 1 IN/OUT	I/O	Channel Y1 in/out
6	INH	I	Disables all channels. See <a href="#">Table 8-1</a> .
7	V <sub>EE</sub>	—	Negative power input
8	V <sub>SS</sub>	—	Ground
9	B	I	Channel select B. See <a href="#">Table 8-1</a> .
10	A	I	Channel select A. See <a href="#">Table 8-1</a> .
11	X CH 3 IN/OUT	I/O	Channel X3 in/out
12	X CH 0 IN/OUT	I/O	Channel X0 in/out
13	X COM IN/OUT	I/O	X common out/in
14	X CH 1 IN/OUT	I/O	Channel in/out
15	X CH 2 IN/OUT	I/O	Channel in/out
16	V <sub>DD</sub>	—	Positive power input

(1) I = input, O = output

**Table 5-3. Pin Functions CD4053B**

PIN		TYPE <sup>(1)</sup>	DESCRIPTION
NO.	NAME		
1	BY IN/OUT	I/O	B channel Y in/out
2	BX IN/OUT	I/O	B channel X in/out
3	CY IN/OUT	I/O	C channel Y in/out
4	CX OR CY OUT/IN	I/O	C common out/in
5	CX IN/OUT	I/O	C channel X in/out
6	INH	I	Disables all channels. See <a href="#">Table 8-1</a> .
7	V <sub>EE</sub>	—	Negative power input
8	V <sub>SS</sub>	—	Ground
9	C	I	Channel select C. See <a href="#">Table 8-1</a> .
10	B	I	Channel select B. See <a href="#">Table 8-1</a> .
11	A	I	Channel select A. See <a href="#">Table 8-1</a> .
12	AX IN/OUT	I/O	A channel X in/out
13	AY IN/OUT	I/O	A channel Y in/out
14	AX OR AY OUT/IN	I/O	A common out/in
15	BX OR BY OUT/IN	I/O	B common out/in
16	V <sub>DD</sub>	—	Positive power input

(1) I = input, O = output

## 6 Specifications

### 6.1 Absolute Maximum Ratings

over operating free-air temperature range (unless otherwise noted)<sup>(1) (2)</sup>

			MIN	MAX	UNIT
	Supply Voltage	V+ to V-, Voltages Referenced to V <sub>SS</sub> Terminal	-0.5	20	V
	DC Input Voltage		-0.5	V <sub>DD</sub> +0.5	V
	DC Input Current	Any One Input	-10	10	mA
T <sub>JMAX1</sub>	Maximum junction temperature, ceramic package			175	°C
T <sub>JMAX2</sub>	Maximum junction temperature, plastic package			150	°C
T <sub>stg</sub>	Storage temperature		-65	150	°C

- (1) Stresses beyond those listed under *Absolute Maximum Rating* may cause permanent damage to the device. These are stress ratings only, which do not imply functional operation of the device at these or any other conditions beyond those indicated under *Recommended Operating Condition*. Exposure to absolute-maximum-rated conditions for extended periods may affect device reliability.
- (2) All voltages are with respect to ground, unless otherwise specified.

### 6.2 ESD Ratings

			VALUE	UNIT
CD4051B in PDIP, CDIP, SOIC, and SOP Packages				
V <sub>(ESD)</sub>	Electrostatic discharge	Human body model (HBM), per ANSI/ESDA/ JEDEC JS-001, all pins <sup>(1)</sup>	±3000	V
		Charged device model (CDM), per JEDEC specification JESD22-C101, all pins <sup>(2)</sup>	±2000	
CD4053B in PDIP, CDIP and SOP Packages				
V <sub>(ESD)</sub>	Electrostatic discharge	Human body model (HBM), per ANSI/ESDA/ JEDEC JS-001, all pins <sup>(1)</sup>	±2500	V
		Charged device model (CDM), per JEDEC specification JESD22-C101, all pins <sup>(2)</sup>	±1500	
CD4051B and CD4053B in TSSOP Package				
V <sub>(ESD)</sub>	Electrostatic discharge	Human body model (HBM), per ANSI/ESDA/ JEDEC JS-001, all pins <sup>(1)</sup>	±2000	V
		Charged device model (CDM), per JEDEC specification JESD22-C101, all pins <sup>(2)</sup>	±500	

- (1) JEDEC document JEP155 states that 500-V HBM allows safe manufacturing with a standard ESD control process.
- (2) JEDEC document JEP157 states that 250-V CDM allows safe manufacturing with a standard ESD control process.

### 6.3 Recommended Operating Conditions

over operating free-air temperature range (unless otherwise noted)

	MIN	NOM	MAX	UNIT
Temperature Range	-55		125	°C

### 6.4 Thermal Information

THERMAL METRIC <sup>(1)</sup>		CD405x				UNIT
		E (PDIP)	M (SOIC)	NS (SOP)	PW (TSSOP)	
		16 PINS	16 PINS	16 PINS	16 PINS	
R <sub>θJA</sub>	Junction-to-ambient thermal resistance	67	73	64	116.5	°C/W

- (1) For more information about traditional and new thermal metrics, see the [Semiconductor and IC Package Thermal Metrics](#) application report.

## 6.5 Electrical Characteristics – TSSOP Package

Over operating free-air temperature range,  $V_{SUPPLY} = \pm 5\text{ V}$ , and  $R_L = 100\ \Omega$ , (unless otherwise noted)<sup>(1)</sup>

PARAMETER	TEST CONDITIONS					MIN	TYP	MAX	UNIT			
	$V_{IS}$ (V)	$V_{EE}$ (V)	$V_{SS}$ (V)	$V_{DD}$ (V)	TEMP							
<b>Signal Inputs (<math>V_{IS}</math>) and Outputs (<math>V_{OS}</math>) – TSSOP Package</b>												
Quiescent Device Current, $I_{DD}$ (Max)		0 V	0 V	5 V	-55°C			60	$\mu\text{A}$			
					-40°C			60				
					25°C		17	60				
					85°C			150				
					125°C			150				
		0 V	0 V	10 V	-55°C			60				
					-40°C			60				
					25°C		18	60				
					85°C			300				
					125°C			300				
		0 V	0 V	15 V	-55°C			60				
					-40°C			60				
					25°C		18	60				
					85°C			600				
					125°C			600				
		0 V	0 V	20 V	-55°C			100				
					-40°C			100				
					25°C		18	100				
					85°C			3000				
					125°C			3000				
Drain to Source ON Resistance $r_{ON}$ (Max) $0 \leq V_{IS} \leq V_{DD}$		0 V	0 V	5 V	-55°C			800	$\Omega$			
					-40°C			850				
					25°C		470	1050				
					85°C			1200				
					125°C			1300				
		0 V	0 V	10 V	-55°C			310				
					-40°C			300				
					25°C		180	400				
					85°C			520				
					125°C			550				
		0 V	0	15 V	-55°C			200				
					-40°C			210				
					25°C		125	240				
					85°C			300				
					125°C			300				
Change in ON Resistance (Between Any Two Channels), $\Delta R_{ON}$		0 V	0 V	5 V	25°C			15	$\Omega$			
						0 V	0 V	10 V				10
										0 V	0 V	15 V

## 6.5 Electrical Characteristics – TSSOP Package (continued)

Over operating free-air temperature range,  $V_{SUPPLY} = \pm 5\text{ V}$ , and  $R_L = 100\ \Omega$ , (unless otherwise noted)<sup>(1)</sup>

PARAMETER		TEST CONDITIONS					MIN	TYP	MAX	UNIT
		$V_{IS}$ (V)	$V_{EE}$ (V)	$V_{SS}$ (V)	$V_{DD}$ (V)	TEMP				
OFF Channel Leakage Current: Any Channel OFF (Max) or All Channels OFF (COMMON OUT/IN) (Max)			0 V	0 V	18 V	-55°C		± 100	nA	
						-40°C				
						25°C		± 0.3 100 <sup>(2)</sup>		
						85°C		± 1000 <sup>(2)</sup>		
						125°C				
ON Channel Leakage Current: Any Channel ON (Max) or All Channels ON (COMMON OUT/IN) (Max)		5 or 0	-5 V	0 V	10.5 V	85°C		± 800	nA	
							5	0 V		0 V
Capacitance	Input, $C_{IS}$	0 V	0 V	10 V	25°C			5	pF	
	Output, $C_{OS}$						CD4051	30		
	Output, $C_{OS}$						CD4052	18		
	Output, $C_{OS}$						CD4053	9		
	Feed-through, $C_{IOS}$							0.2		
Prop Delay		$V_{DD}$	$R_L = 200\text{ k}\Omega$		25°C			30 60	ns	
			$C_L = 50\text{ pF}$					15 30		
			$t_r, t_f = 20\text{ ns}$					10 20		

### 6.5 Electrical Characteristics – TSSOP Package (continued)

Over operating free-air temperature range,  $V_{SUPPLY} = \pm 5\text{ V}$ , and  $R_L = 100\ \Omega$ , (unless otherwise noted)<sup>(1)</sup>

PARAMETER		TEST CONDITIONS					MIN	TYP	MAX	UNIT
		$V_{IS}$ (V)	$V_{EE}$ (V)	$V_{SS}$ (V)	$V_{DD}$ (V)	TEMP				
<b>CONTROL (ADDRESS OR INHIBIT), <math>V_C</math> - TSSOP Package</b>										
Input Low Voltage, $V_{IL}$ , (Max)					5 V	-55°C	0.8		V	
						-40°C	0.8			
						25°C	0.8			
						85°C	0.8			
						125°C	0.8			
					10 V	-55°C	0.8			
						-40°C	0.8			
						25°C	0.8			
						85°C	0.8			
						125°C	0.8			
					15 V	-55°C	0.8			
						-40°C	0.8			
						25°C	0.8			
						85°C	0.8			
						125°C	0.8			
Input High Voltage, $V_{IH}$ , (Min)					5 V	-55°C	3.5		V	
						-40°C	3.5			
						25°C	3.5			
						85°C	3.5			
						125°C	3.5			
					10 V	-55°C	7			
						-40°C	7			
						25°C	7			
						85°C	7			
						125°C	7			
					15 V	-55°C	11			
						-40°C	11			
						25°C	11			
						85°C	11			
						125°C	11			
Input current, $I_{IN}$ (Max)					18 V	-55°C	±1		µA	
						-40°C	±1			
						25°C	±0.6			
						85°C	±1			
						125°C	±1			
Propagation Delay Time	Address-to-Signal OUT (Channels ON or OFF) (See Figure 7-2 Figure 7-3, and Figure 7-8)	$t_r, t_f = 20\text{ ns}$ , $C_L = 50\text{ pF}$ , $R_L = 10\text{ k}\Omega$	0 V	0 V	5 V		450	720	ns	
			0 V	0 V	10 V		160	320		
			0 V	0 V	15 V		120	240		
			-5 V	0 V	5 V		225	450		



## 6.5 Electrical Characteristics – TSSOP Package (continued)

Over operating free-air temperature range,  $V_{\text{SUPPLY}} = \pm 5 \text{ V}$ , and  $R_L = 100 \Omega$ , (unless otherwise noted)<sup>(1)</sup>

PARAMETER		TEST CONDITIONS					MIN	TYP	MAX	UNIT
		$V_{\text{IS}}$ (V)	$V_{\text{EE}}$ (V)	$V_{\text{SS}}$ (V)	$V_{\text{DD}}$ (V)	TEMP				
Propagation Delay Time	Inhibit-to-Signal OUT (Channel Turning ON) (See Figure 7-3)	$t_r, t_f = 20 \text{ ns}$ , $C_L = 50 \text{ pF}$ , $R_L = 1 \text{ k}\Omega$	0 V	0 V	5 V		400	720	ns	
			0 V	0 V	10 V		160	320		
			0 V	0 V	15 V		120	240		
			-10 V	0 V	5 V		200	400		
Propagation Delay Time	Inhibit-to-Signal OUT (Channel Turning OFF) (See Figure 7-10)	$t_r, t_f = 20 \text{ ns}$ , $C_L = 50 \text{ pF}$ , $R_L = 10 \text{ k}\Omega$	0 V	0 V	5 V		200	450	ns	
			0 V	0 V	10 V		90	210		
			0 V	0 V	15 V		70	160		
			-10 V	0 V	5 V		130	300		
Input Capacitance, $C_{\text{IN}}$ (Any Address or Inhibit Input)			-5 V	0 V	5 V	25°C	5	7.5	pF	

- (1) Peak-to-Peak voltage symmetrical about  $(V_{\text{DD}} - V_{\text{EE}}) / 2$ .  
(2) Determined by minimum feasible leakage measurement for automatic testing.

## 6.6 AC Performance Characteristics – TSSOP Package

$V_{DD} = +15\text{ V}$ ,  $V_{SS} = V_{EE} = 0\text{ V}$ ,  
 $T_A = 25^\circ\text{C}$  (unless otherwise noted)

PARAMETER	TEST CONDITIONS			TYP	UNIT			
	$V_{IS}$ (V)	$V_{DD}$ (V)	$R_L$ (k $\Omega$ )					
Cutoff (–3 dB) Frequency Channel ON (Sine Wave Input)	5 <sup>(1)</sup>	10	1	$V_{OS}$ at Common OUT/IN	CD4053	30	MHz	
		10	1		CD4052	25		
		10	1		CD4051	20		
	$V_{EE} = V_{SS}$ , $20\text{Log}(V_{OS}/V_{IS}) = -3\text{ dB}$			$V_{OS}$ at Any Channel		60		
Total Harmonic Distortion, THD	2 <sup>(1)</sup>	5	10			0.3%	%	
	3 <sup>(1)</sup>	10	10		0.2%			
	5 <sup>(1)</sup>	15	10		0.12%			
	$V_{EE} = V_{SS}$ , $f_{IS} = 1\text{ kHz}$ Sine Wave							
–40 dB Feed-through Frequency (All Channels OFF)	5 <sup>(1)</sup>	10	1	$V_{OS}$ at Common OUT/IN	CD4053	8	MHz	
					CD4052	10		
					CD4051	12		
	$V_{EE} = V_{SS}$ , $20\text{Log}(V_{OS}/V_{IS}) = -40\text{ dB}$			$V_{OS}$ at Any Channel		8		
–40 dB Signal Crosstalk Frequency	5 <sup>(1)</sup>	10	1			3	MHz	
					Between Sections, CD4052 Only	Measured on Common		6
						Measured on Any Channel		10
					Between Any Two Sections, CD4053 Only	In Pin 2, Out Pin 14		2.5
						In Pin 15, Out Pin 14		6
					Address-or-Inhibit-to- Signal Crosstalk			10
$V_{EE} = 0$ , $V_{SS} = 0$ , $t_r$ , $t_f = 20\text{ ns}$ , mV <sub>PEAK</sub> $V_{CC} = V_{DD} - V_{SS}$ (Square Wave)		65	mV <sub>PEAK</sub>					

- (1) Peak-to-Peak voltage symmetrical about  $(V_{DD} - V_{EE}) / 2$ .  
(2) Both ends of channel.

## 6.7 Electrical Characteristics – CDIP, PDIP, SOIC and SOP Packages

Over operating free-air temperature range,  $V_{\text{SUPPLY}} = \pm 5 \text{ V}$ , and  $R_L = 100 \Omega$ , (unless otherwise noted)<sup>(1)</sup>

PARAMETER	TEST CONDITIONS					MIN	TYP	MAX	UNIT			
	$V_{\text{IS}}$ (V)	$V_{\text{EE}}$ (V)	$V_{\text{SS}}$ (V)	$V_{\text{DD}}$ (V)	TEMP							
<b>Signal Inputs (<math>V_{\text{IS}}</math>) and Outputs (<math>V_{\text{OS}}</math>) – CDIP, PDIP, SOIC and SOP Packages</b>												
Quiescent Device Current, $I_{\text{DD Max}}$	0 V	0 V	0 V	5 V	-55°C			5	$\mu\text{A}$			
					-40°C			5				
					25°C	0.04		5				
					85°C			150				
					125°C			150				
	0 V	0 V	0 V	10 V	-55°C			10				
					-40°C			10				
					25°C	0.04		10				
					85°C			300				
					125°C			300				
	0 V	0 V	0 V	15 V	-55°C			20				
					-40°C			20				
					25°C	0.04		20				
					85°C			600				
					125°C			600				
	0 V	0 V	0 V	20 V	-55°C			100				
					-40°C			100				
					25°C	18		100				
					85°C			3000				
					125°C			3000				
Drain to Source ON Resistance $r_{\text{ON Max}}$ $0 \leq V_{\text{IS}} \leq V_{\text{DD}}$	0 V	0 V	0 V	5 V	-55°C			800	$\Omega$			
					-40°C			850				
					25°C	470		1050				
					85°C			1200				
					125°C			1300				
	0 V	0 V	0 V	10 V	-55°C			310				
					-40°C			300				
					25°C	180		400				
					85°C			520				
					125°C			550				
	0 V	0	0	15 V	-55°C			200				
					-40°C			210				
					25°C	125		240				
					85°C			300				
					125°C			300				
Change in ON Resistance (Between Any Two Channels), $\Delta R_{\text{ON}}$	0 V	0 V	0 V	5 V	25°C			15	$\Omega$			
						0 V	0 V	10 V				10
										0 V	0 V	15 V

## 6.7 Electrical Characteristics – CDIP, PDIP, SOIC and SOP Packages (continued)

Over operating free-air temperature range,  $V_{SUPPLY} = \pm 5\text{ V}$ , and  $R_L = 100\ \Omega$ , (unless otherwise noted)<sup>(1)</sup>

PARAMETER		TEST CONDITIONS					MIN	TYP	MAX	UNIT
		$V_{IS}$ (V)	$V_{EE}$ (V)	$V_{SS}$ (V)	$V_{DD}$ (V)	TEMP				
OFF Channel Leakage Current: Any Channel OFF (Max) or ALL Channels OFF (COMMON OUT/IN) (Max)			0 V	0 V	18 V	-55°C	± 100		nA	
						-40°C				
						25°C	± 0.01	± 100 <sup>(2)</sup>		
						85°C	± 1000 <sup>(2)</sup>			
						125°C				
ON Channel Leakage Current: Any Channel ON (Max) or ALL Channels ON (COMMON OUT/IN) (Max)		5 or 0	-5 V	0 V	10.5 V	85°C	± 300		nA	
		5	0 V	0 V	18 V	85°C	± 300			
Capacitance	Input, $C_{IS}$	0 V	0 V	10 V	25°C	5		pF		
	Output, $C_{OS}$					CD4051	30			
	Output, $C_{OS}$					CD4052	18			
	Output, $C_{OS}$					CD4053	9			
	Feed-through, $C_{IOS}$					0.2				
Prop Delay		$V_{DD}$	$R_L = 200\text{ k}\Omega$		5 V	25°C	30	60	ns	
			$C_L = 50\text{ pF}$		10 V		15	30		
			$t_r, t_f = 20\text{ ns}$		15 V		10	20		

## 6.7 Electrical Characteristics – CDIP, PDIP, SOIC and SOP Packages (continued)

Over operating free-air temperature range,  $V_{\text{SUPPLY}} = \pm 5 \text{ V}$ , and  $R_L = 100 \Omega$ , (unless otherwise noted)<sup>(1)</sup>

PARAMETER		TEST CONDITIONS					MIN	TYP	MAX	UNIT
		$V_{\text{IS}}$ (V)	$V_{\text{EE}}$ (V)	$V_{\text{SS}}$ (V)	$V_{\text{DD}}$ (V)	TEMP				
<b>CONTROL (ADDRESS OR INHIBIT), <math>V_C</math> - CDIP, PDIP, SOIC and SOP Packages</b>										
Input Low Voltage, $V_{\text{IL}}$ , Max						5 V	-55°C	1.5		V
							-40°C	1.5		
							25°C	1.5		
							85°C	1.5		
							125°C	1.5		
						10 V	-55°C	3		
							-40°C	3		
							25°C	3		
							85°C	3		
							125°C	3		
						15 V	-55°C	4		
							-40°C	4		
							25°C	4		
							85°C	4		
							125°C	4		
Input High Voltage, $V_{\text{IH}}$ , Min						5 V	-55°C	3.5		V
							-40°C	3.5		
							25°C	3.5		
							85°C	3.5		
							125°C	3.5		
						10 V	-55°C	7		
							-40°C	7		
							25°C	7		
							85°C	7		
							125°C	7		
						15 V	-55°C	11		
							-40°C	11		
							25°C	11		
							85°C	11		
							125°C	11		
Input current, $I_{\text{IN}}$ (Max)						18 V	-55°C	$\pm 0.1$		$\mu\text{A}$
							-40°C	$\pm 0.1$		
							25°C	$\pm 10^{-5} \pm 0.1$		
							85°C	$\pm 1$		
							125°C	$\pm 1$		
Propagation Delay Time	Address-to-Signal OUT (Channels ON or OFF) (See Figure 7-2 Figure 7-3, and Figure 7-8)	$t_r, t_f = 20\text{ns}$ , $C_L = 50 \text{ pF}$ , $R_L = 10 \text{ k}\Omega$	0 V	0 V	5 V		450	720		ns
			0 V	0 V	10 V		160	320		
			0 V	0 V	15 V		120	240		
			-5 V	0 V	5 V		225	450		

## 6.7 Electrical Characteristics – CDIP, PDIP, SOIC and SOP Packages (continued)

 Over operating free-air temperature range,  $V_{SUPPLY} = \pm 5\text{ V}$ , and  $R_L = 100\ \Omega$ , (unless otherwise noted)<sup>(1)</sup>

PARAMETER		TEST CONDITIONS					MIN	TYP	MAX	UNIT
		$V_{IS}$ (V)	$V_{EE}$ (V)	$V_{SS}$ (V)	$V_{DD}$ (V)	TEMP				
Propagation Delay Time	Inhibit-to-Signal OUT (Channel Turning ON) (See Figure 7-3)	$t_r, t_f = 20\text{ ns}$ , $C_L = 50\text{ pF}$ , $R_L = 1\text{ k}\Omega$	0 V	0 V	5 V		400	720	ns	
			0 V	0 V	10 V		160	320		
			0 V	0 V	15 V		120	240		
			-10 V	0 V	5 V		200	400		
Propagation Delay Time	Inhibit-to-Signal OUT (Channel Turning OFF) (See Figure 7-10)	$t_r, t_f = 20\text{ ns}$ , $C_L = 50\text{ pF}$ , $R_L = 10\text{ k}\Omega$	0 V	0 V	5 V		200	450	ns	
			0 V	0 V	10 V		90	210		
			0 V	0 V	15 V		90	160		
			-10 V	0 V	5 V		130	300		
Input Capacitance, $C_{IN}$ (Any Address or Inhibit Input)			-5 V	0 V	5 V	25°C	5	7.5	pF	

 (1) Peak-to-Peak voltage symmetrical about  $(V_{DD} - V_{EE}) / 2$ .

(2) Determined by minimum feasible leakage measurement for automatic testing.

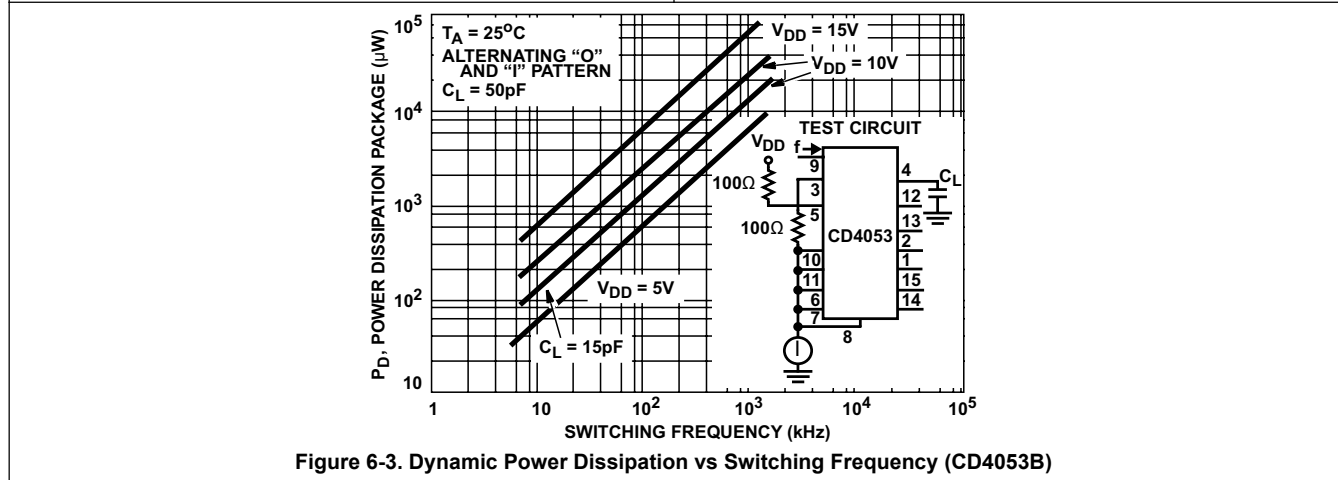
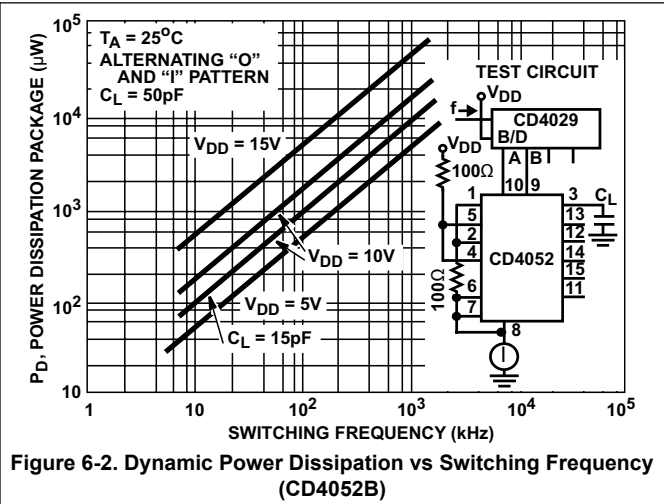
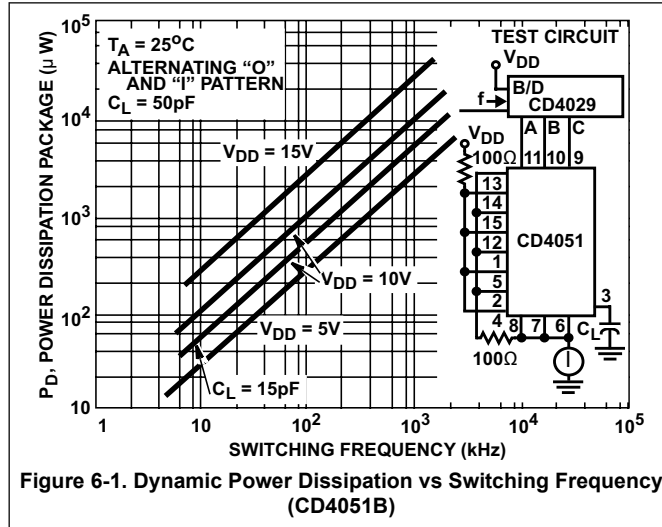
## 6.8 AC Performance Characteristics – CDIP, PDIP, SOIC and SOP Packages

$V_{DD} = +15\text{ V}$ ,  $V_{SS} = V_{EE} = 0\text{ V}$ ,  
 $T_A = 25^\circ\text{C}$  (unless otherwise noted)

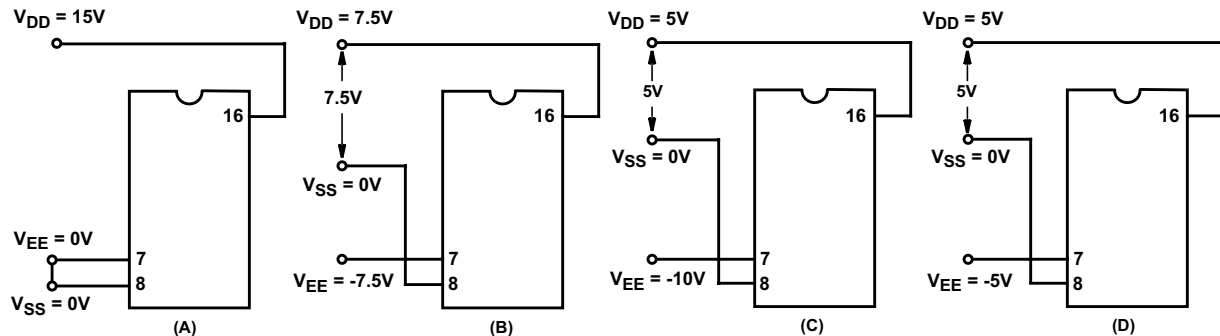
PARAMETER	TEST CONDITIONS			TYP	UNIT					
	$V_{IS}$ (V)	$V_{DD}$ (V)	$R_L$ (k $\Omega$ )							
Cutoff (–3 dB) Frequency Channel ON (Sine Wave Input)	5 <sup>(1)</sup>	10	1	$V_{OS}$ at Common OUT/IN	CD4053	30	MHz			
		10	1		CD4052	25				
		10	1		CD4051	20				
	$V_{EE} = V_{SS}$ , $20\text{Log}(V_{OS}/V_{IS}) = -3\text{ dB}$			$V_{OS}$ at Any Channel		60				
Total Harmonic Distortion, THD	2 <sup>(1)</sup>	5	10			0.3%	%			
	3 <sup>(1)</sup>	10	10			0.2%				
	5 <sup>(1)</sup>	15	10			0.12%				
	$V_{EE} = V_{SS}$ , $f_{IS} = 1\text{ kHz}$ Sine Wave									
–40 dB Feed-through Frequency (All Channels OFF)	5 <sup>(1)</sup>	10	1	$V_{OS}$ at Common OUT/IN	CD4053	8	MHz			
					CD4052	10				
					CD4051	12				
	$V_{EE} = V_{SS}$ , $20\text{Log}(V_{OS}/V_{IS}) = -40\text{ dB}$			$V_{OS}$ at Any Channel		8				
–40 dB Signal Crosstalk Frequency	5 <sup>(1)</sup>	10	1			3	MHz			
						$V_{EE} = V_{SS}$ , $20\text{Log}(V_{OS}/V_{IS}) = -3\text{ dB}$		Between Sections, CD4052 Only	Measured on Common	6
									Measured on Any Channel	10
						$V_{EE} = V_{SS}$ , $20\text{Log}(V_{OS}/V_{IS}) = -3\text{ dB}$		Between Any Two Sections, CD4053 Only	In Pin 2, Out Pin 14	2.5
									In Pin 15, Out Pin 14	6
						Address-or-Inhibit-to- Signal Crosstalk			10	10 <sup>(2)</sup>
$V_{EE} = 0$ , $V_{SS} = 0$ , $t_r$ , $t_f = 20\text{ ns}$ , mV <sub>PEAK</sub> $V_{CC} = V_{DD} - V_{SS}$ (Square Wave)	65	mV <sub>PEAK</sub>								

- (1) Peak-to-Peak voltage symmetrical about  $(V_{DD} - V_{EE}) / 2$ .  
(2) Both ends of channel.

## 6.9 Typical Characteristics



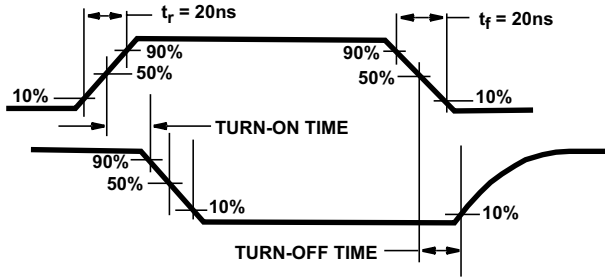
## 7 Parameter Measurement Information



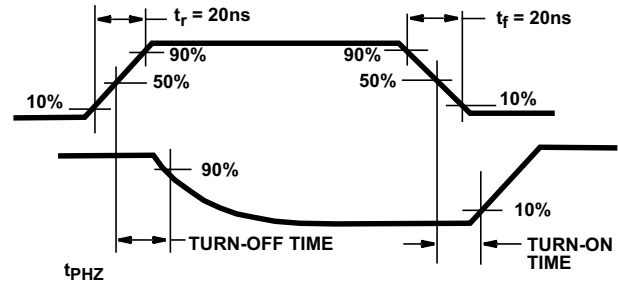


**Note**

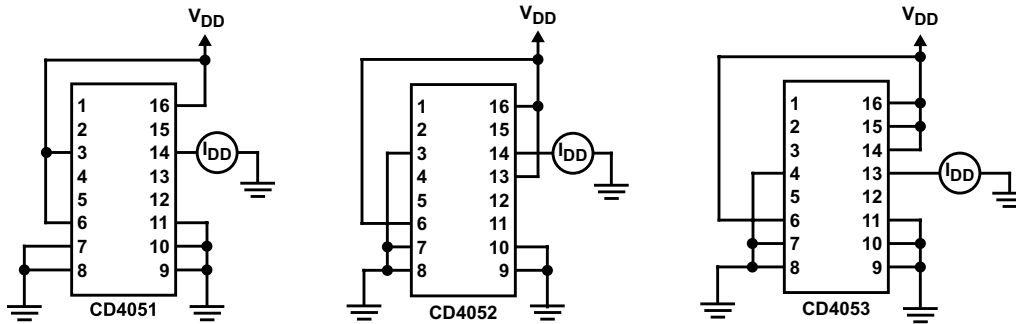
The ADDRESS (digital-control inputs) and INHIBIT logic levels are: 0 =  $V_{SS}$  and 1 =  $V_{DD}$ . The analog signal (through the TG) may swing from  $V_{EE}$  to  $V_{DD}$ .



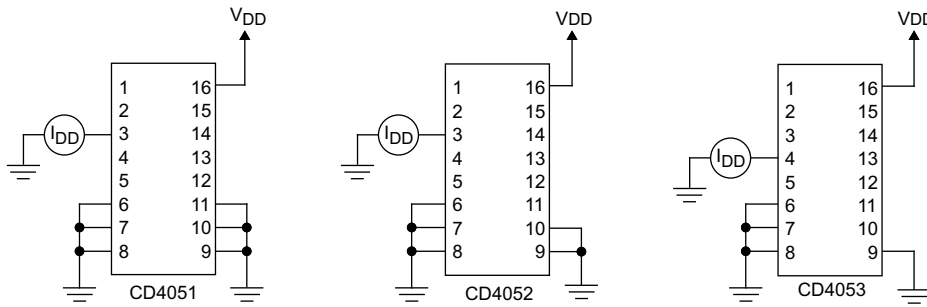
**Figure 7-2. Waveforms, Channel Being Turned ON ( $R_L = 1\text{ k}\Omega$ )**



**Figure 7-3. Waveforms, Channel Being Turned OFF ( $R_L = 1\text{ k}\Omega$ )**

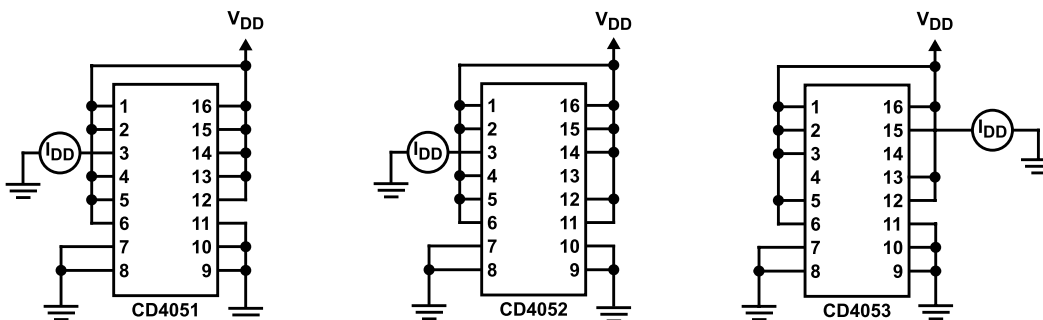


**Figure 7-4. OFF Channel Leakage Current – Any Channel OFF**



Copyright © 2017, Texas Instruments Incorporated

**Figure 7-5. On Channel Leakage Current – Any Channel On**



**Figure 7-6. OFF Channel Leakage Current – All Channels OFF**

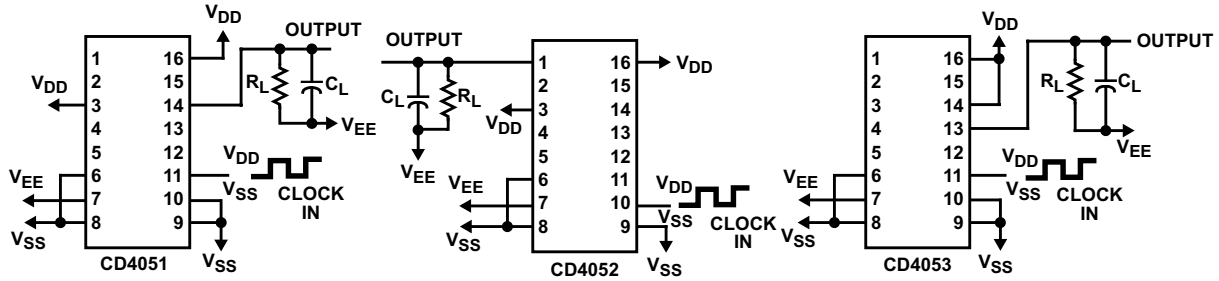


Figure 7-7. Propagation Delay – Address Input to Signal Output

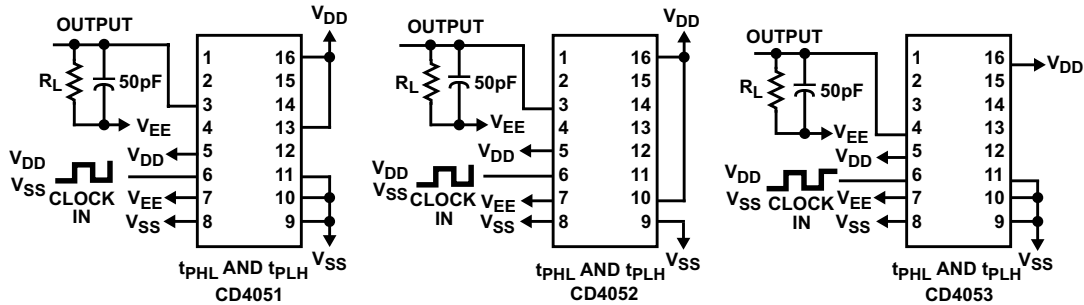
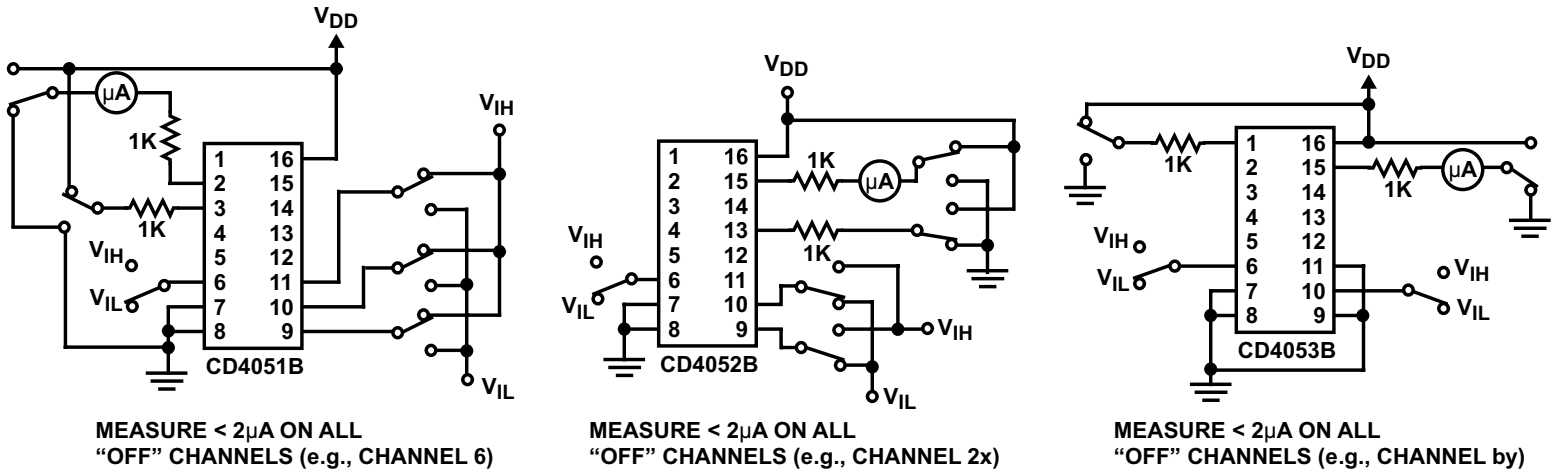


Figure 7-8. Propagation Delay – Inhibit Input to Signal Output



MEASURE < 2µA ON ALL  
“OFF” CHANNELS (e.g., CHANNEL 6)

MEASURE < 2µA ON ALL  
“OFF” CHANNELS (e.g., CHANNEL 2x)

MEASURE < 2µA ON ALL  
“OFF” CHANNELS (e.g., CHANNEL by)

Figure 7-9. Input Voltage Test Circuits (Noise Immunity)

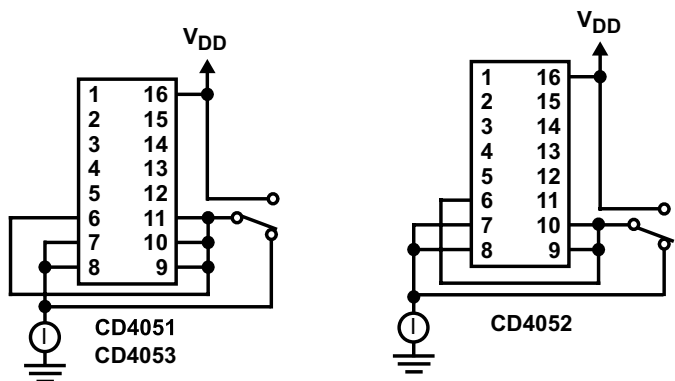


Figure 7-10. Quiescent Device Current

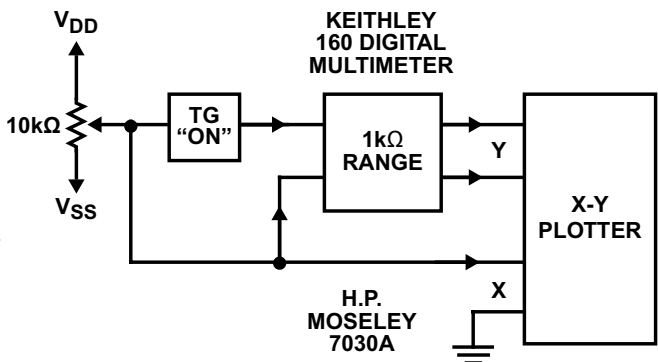


Figure 7-11. Channel ON Resistance Measurement Circuit

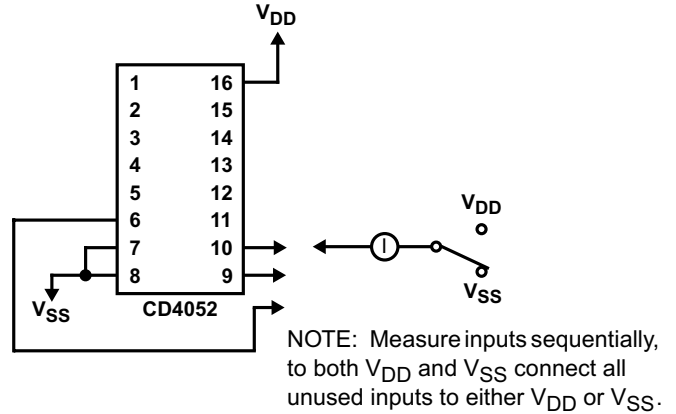
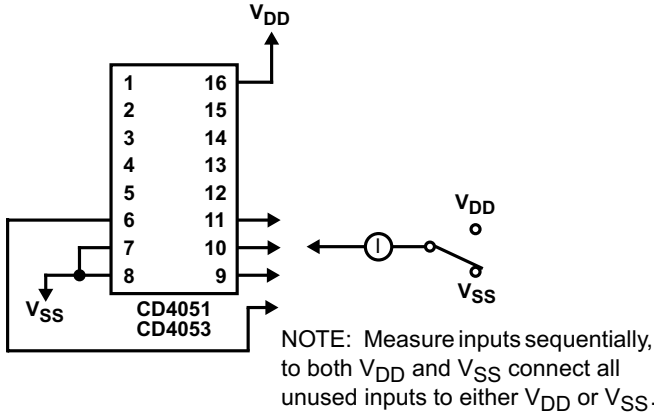


Figure 7-12. Input Current

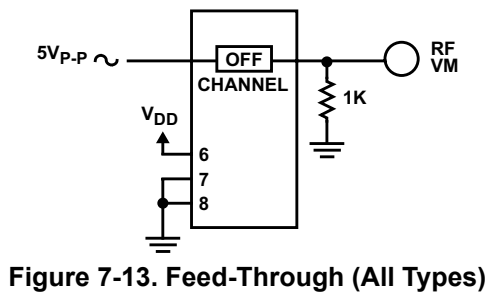


Figure 7-13. Feed-Through (All Types)

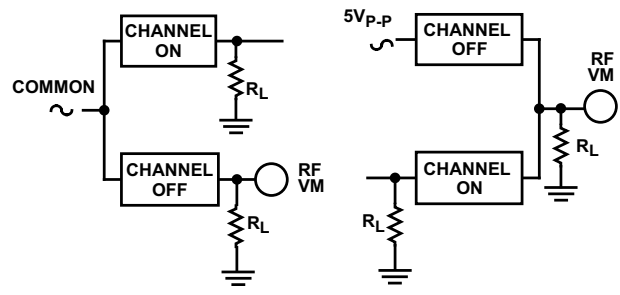
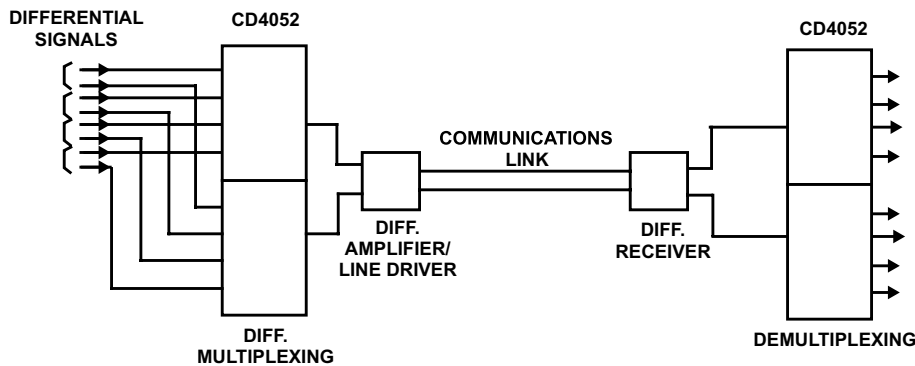


Figure 7-14. Crosstalk Between Any Two Channels (All Types)



Figure 7-15. Crosstalk Between Duals or Triplets (CD4052B, CD4053B)



**Special Considerations:** In applications where separate power sources are used to drive  $V_{DD}$  and the signal inputs, the  $V_{DD}$  current capability should exceed  $V_{DD}/R_L$  ( $R_L$  = effective external load). This provision avoids permanent current flow or clamp action on the  $V_{DD}$  supply when power is applied or removed from the CD4051B, CD4052B or CD4053B.

Figure 7-16. Typical Time-Division Application of the CD4052B

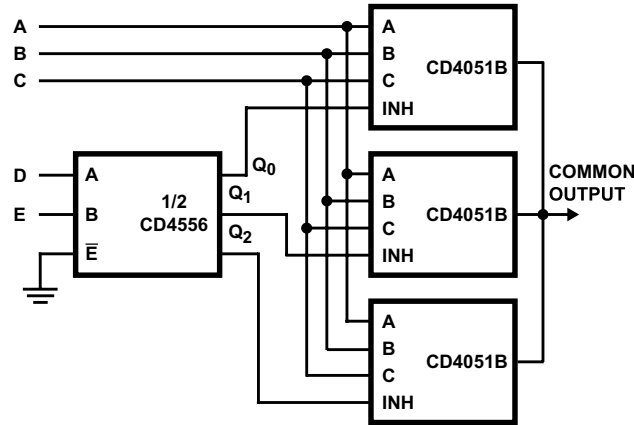


Figure 7-17. 24-to-1 MUX Addressing

## 8 Detailed Description

### 8.1 Overview

The CD4051B, CD4052B, and CD4053B analog multiplexers are digitally-controlled analog switches having low ON impedance and very low OFF leakage current. Control of analog signals up to 20 V<sub>P-P</sub> can be achieved by digital signal amplitudes of 4.5 V to 20 V (if  $V_{DD} - V_{SS} = 3$  V, a  $V_{DD} - V_{EE}$  of up to 13 V can be controlled; for  $V_{DD} - V_{EE}$  level differences above 13 V, a  $V_{DD} - V_{SS}$  of at least 4.5 V is required). For example, if  $V_{DD} = +4.5$  V,  $V_{SS} = 0$  V, and  $V_{EE} = -13.5$  V, analog signals from  $-13.5$  V to  $+4.5$  V can be controlled by digital inputs of 0 V to 5 V. These multiplexer circuits dissipate extremely low quiescent power over the full  $V_{DD} - V_{SS}$  and  $V_{DD} - V_{EE}$  supply-voltage ranges, independent of the logic state of the control signals. When a logic 1 is present at the inhibit input terminal, all channels are off.

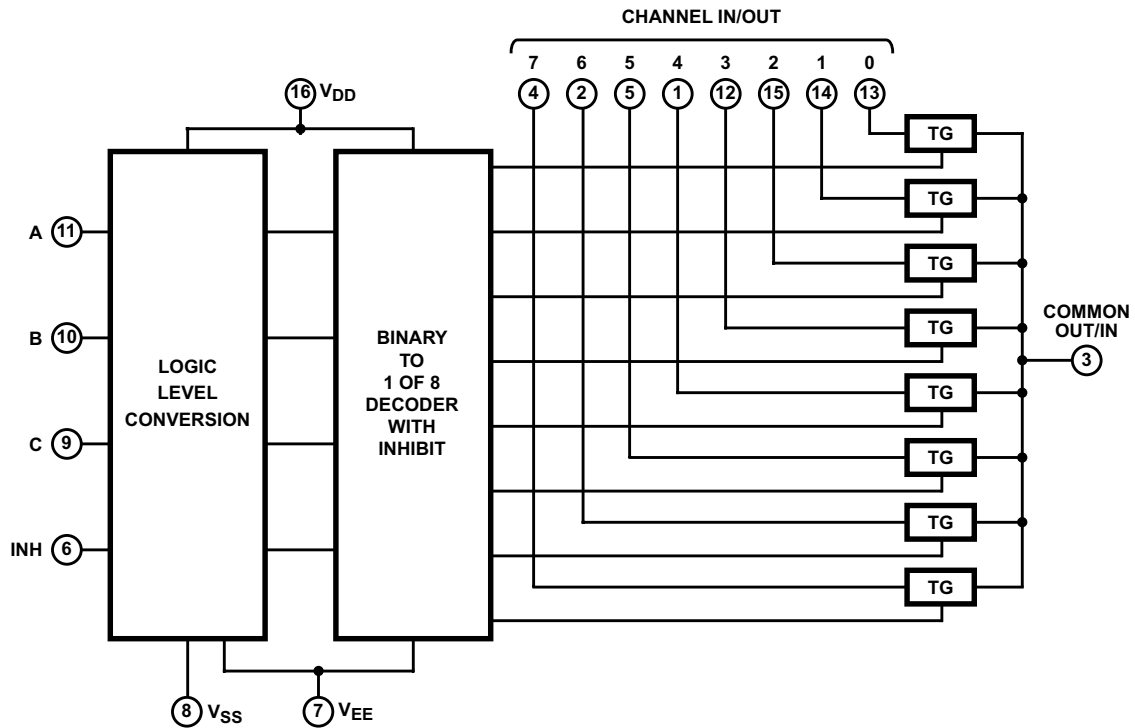
The CD4051B device is a single 8-channel multiplexer having three binary control inputs, A, B, and C, and an inhibit input. The three binary signals select 1 of 8 channels to be turned on, and connect one of the 8 inputs to the output.

The CD4052B device is a differential 4-channel multiplexer having two binary control inputs, A and B, and an inhibit input. The two binary input signals select 1 of 4 pairs of channels to be turned on and connect the analog inputs to the outputs.

The CD4053B device is a triple 2-channel multiplexer having three separate digital control inputs, A, B, and C, and an inhibit input. Each control input selects one of a pair of channels which are connected in a single-pole, double-throw configuration.

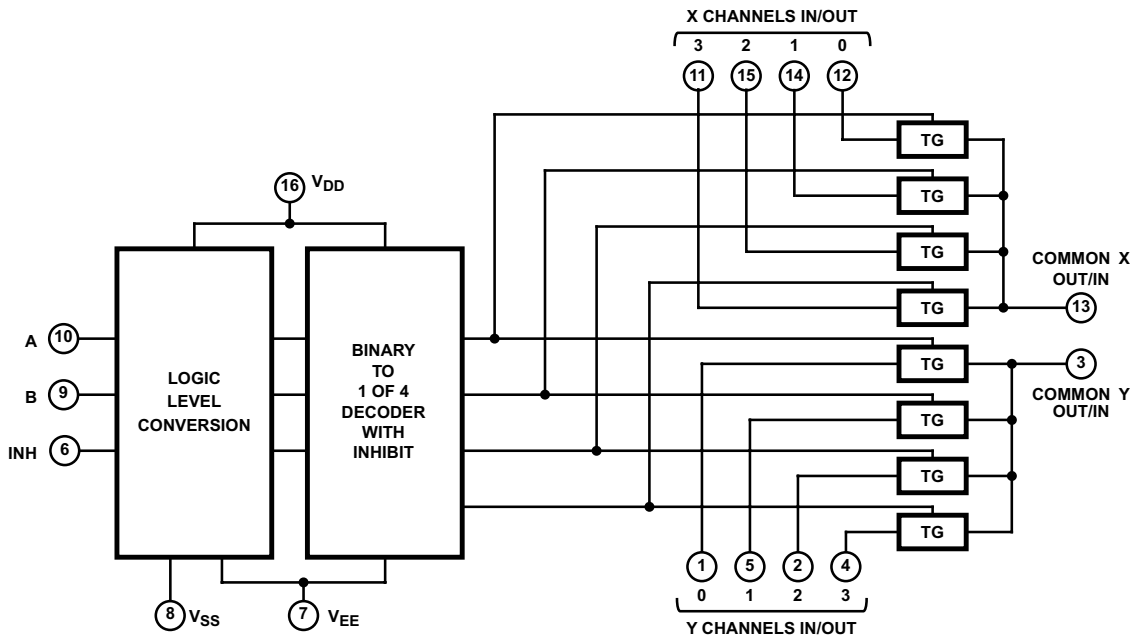
When these devices are used as demultiplexers, the CHANNEL IN/OUT terminals are the outputs and the COMMON OUT/IN terminals are the inputs.

## 8.2 Functional Block Diagrams



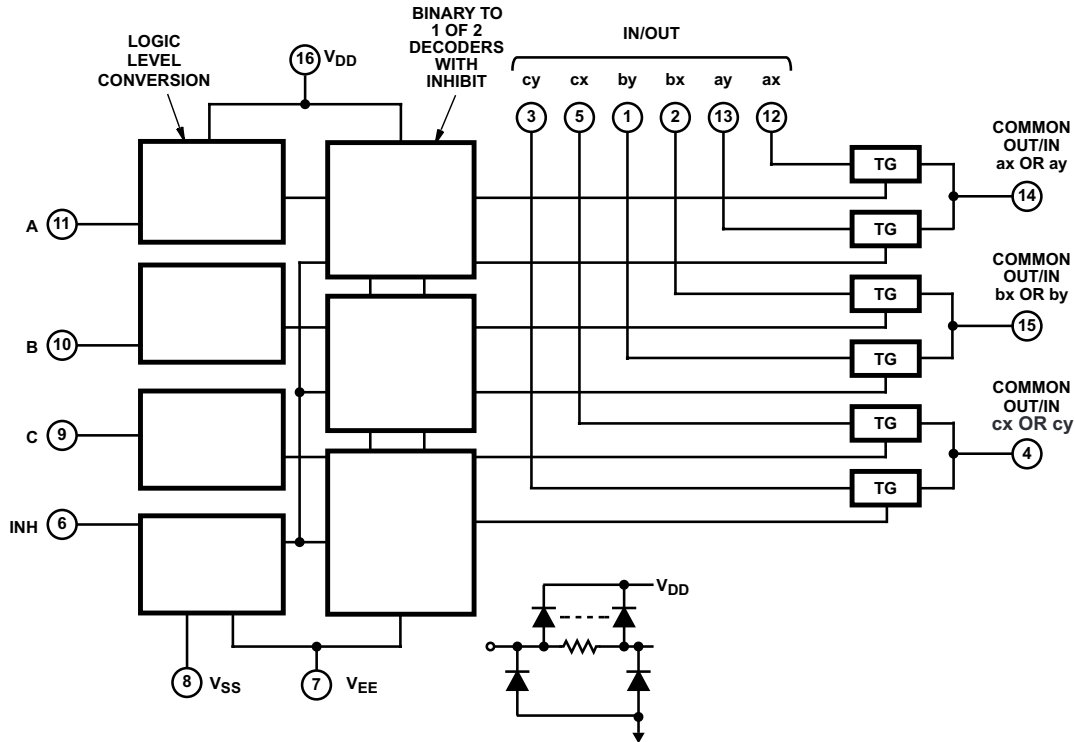
All inputs are protected by standard CMOS protection network.

**Figure 8-1. Functional Block Diagram, CD4051B**



All inputs are protected by standard CMOS protection network.

**Figure 8-2. Functional Block Diagram, CD4052B**



All inputs are protected by standard CMOS protection network.

**Figure 8-3. Functional Block Diagram, CD4053B**

### 8.3 Feature Description

The CD405xB line of multiplexers and demultiplexers can accept a wide range of digital and analog signal levels. Digital signals range from 3 V to 20 V, and analog signals are accepted at levels  $\leq 20$  V. The devices have low ON resistance, typically 125  $\Omega$  over 15 V<sub>P-P</sub> signal input range for  $V_{DD} - V_{EE} = 18$  V. This feature allows for very little signal loss through the switch. Matched switch characteristics are typically  $r_{ON} = 5$   $\Omega$  for  $V_{DD} - V_{EE} = 15$  V.

The CD405xB devices also have high OFF resistance, which keeps from wasting power when the switch is in the OFF position, with typical channel leakage of  $\pm 100$  pA at  $V_{DD} - V_{EE} = 18$  V. Very low quiescent power dissipation under all digital-control input and supply conditions, typically 0.2  $\mu$ W at  $V_{DD} - V_{SS} = V_{DD} - V_{EE} = 10$  V keeps power consumption total very low. All devices have been 100% tested for quiescent current at 20 V with maximum input current of 1  $\mu$ A at 18 V over the full package temperature range, and only 100 nA at 18 V and 25°C.

Logic-level conversion for digital addressing signals of 3 V to 20 V ( $V_{DD} - V_{SS} = 3$  V to 20 V) to switch analog signals to 20 V<sub>P-P</sub> ( $V_{DD} - V_{EE} = 20$  V). Binary address decoding on chip makes channel selection easy. When channels are changed, a break-before-make system eliminates channel overlap.

## 8.4 Device Functional Modes

**Table 8-1. Truth Table<sup>(1)</sup>**

INPUT STATES				ON CHANNEL(S)
INHIBIT	C	B	A	
<b>CD4051B</b>				
0	0	0	0	0
0	0	0	1	1
0	0	1	0	2
0	0	1	1	3
0	1	0	0	4
0	1	0	1	5
0	1	1	0	6
0	1	1	1	7
1	X	X	X	None
<b>CD4052B</b>				
0		0	0	0x, 0y
0		0	1	1x, 1y
0		1	0	2x, 2y
0		1	1	3x, 3y
1		X	X	None
<b>CD4053B</b>				
0	X	X	0	ax
0	X	X	1	ay
0	X	0	X	bx
0	X	1	X	by
0	0	X	X	cx
0	1	X	X	cy
1	X	X	X	None

(1) X = Do not care

## 9 Application and Implementation

### Note

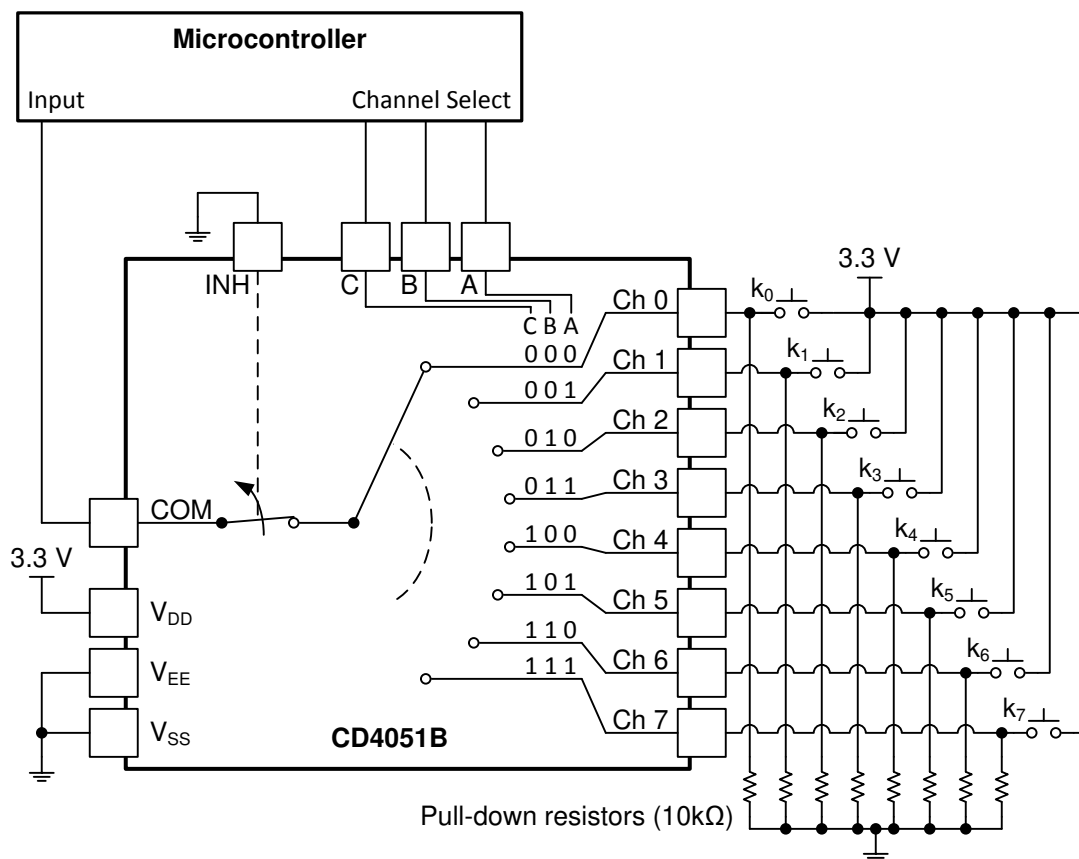
Information in the following applications sections is not part of the TI component specification, and TI does not warrant its accuracy or completeness. TI's customers are responsible for determining suitability of components for their purposes, as well as validating and testing their design implementation to confirm system functionality.

### 9.1 Application Information

The CD405xB multiplexers and demultiplexers can be used for a wide variety of applications.

### 9.2 Typical Application

One application of the CD4051B is to use it in conjunction with a microcontroller to poll a keypad. [Figure 9-1](#) shows the basic schematic for such a polling system. The microcontroller uses the channel select pins to cycle through the different channels while reading the input to see if a user is pressing any of the keys. This application is a very robust setup, allowing for multiple simultaneous key-presses with very little power consumption. This setup also uses very few pins on the microcontroller. The down side of polling is that the microcontroller must continually scan the keys for a press and can do little else during this process.



**Figure 9-1. The CD4051B Being Used to Help Read Button Presses on a Keypad.**

#### 9.2.1 Design Requirements

These devices use CMOS technology and have balanced output drive. Take care to avoid bus contention because it can drive currents that would exceed maximum limits. The high drive will also create fast edges into light loads, so routing and load conditions should be considered to prevent ringing.



## 9.2.2 Detailed Design Procedure

1. Recommended Input Conditions:
  - For switch time specifications, see propagation delay times in [Electrical Characteristics](#).
  - Inputs should not be pushed more than 0.5 V above  $V_{DD}$  or below  $V_{EE}$ .
  - For input voltage level specifications for control inputs, see  $V_{IH}$  and  $V_{IL}$  in [Electrical Characteristics](#).
2. Recommended Output Conditions:
  - Outputs should not be pulled above  $V_{DD}$  or below  $V_{EE}$ .
3. Input or output current consideration:
  - The CD405xB series of parts do not have internal current drive circuitry and thus cannot sink or source current. Any current will be passed through the device.

## 9.2.3 Application Curve

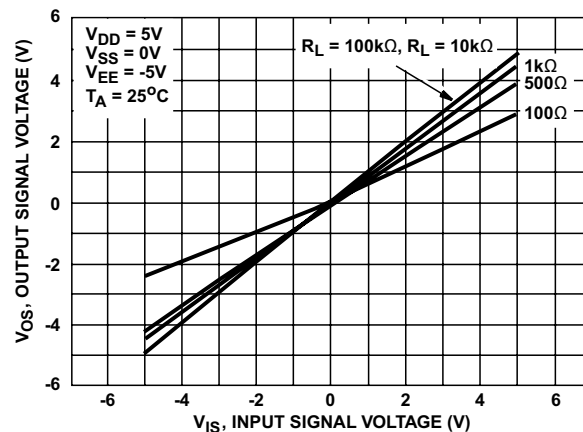


Figure 9-2. ON Characteristics for 1 of 8 Channels (CD4051B)

## 9.3 Power Supply Recommendations

The power supply can be any voltage between the minimum and maximum supply voltage rating located in the [Electrical Characteristics](#).

Each  $V_{CC}$  terminal should have a good bypass capacitor to prevent power disturbance. For devices with a single supply, a 0.1- $\mu\text{F}$  bypass capacitor is recommended. If there are multiple pins labeled  $V_{CC}$ , then a 0.01- $\mu\text{F}$  or 0.022- $\mu\text{F}$  capacitor is recommended for each  $V_{CC}$  because the  $V_{CC}$  pins will be tied together internally. For devices with dual supply pins operating at different voltages, for example  $V_{CC}$  and  $V_{DD}$ , a 0.1- $\mu\text{F}$  bypass capacitor is recommended for each supply pin. It is acceptable to parallel multiple bypass capacitors to reject different frequencies of noise. 0.1- $\mu\text{F}$  and 1- $\mu\text{F}$  capacitors are commonly used in parallel. The bypass capacitor should be installed as close to the power terminal as possible for best results.

## 9.4 Layout

### 9.4.1 Layout Guidelines

Reflections and matching are closely related to loop antenna theory, but different enough to warrant their own discussion. When a PCB trace turns a corner at a 90° angle, a reflection can occur. This reflection is primarily due to the change of width of the trace. At the apex of the turn, the trace width is increased to 1.414 times its width. This upsets the transmission line characteristics, especially the distributed capacitance and self-inductance of the trace — resulting in the reflection. It is a given that not all PCB traces can be straight, and so they will have to turn corners. [Figure 9-3](#) shows progressively better techniques of rounding corners. Only the last example maintains constant trace width and minimizes reflections.

### 9.4.2 Layout Example

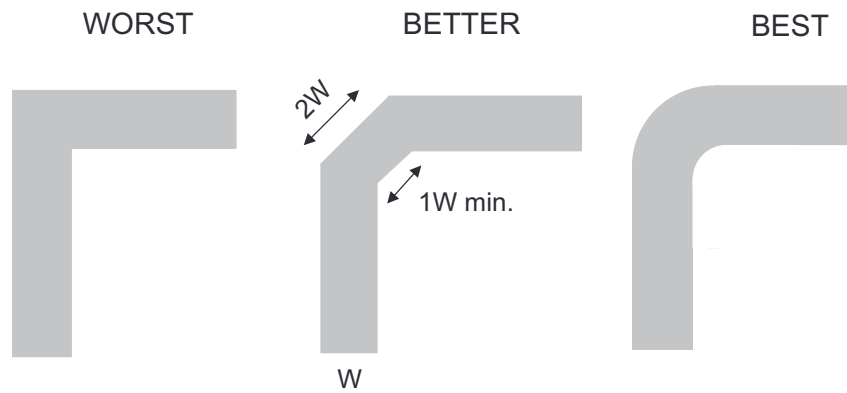


Figure 9-3. Trace Example

## 10 Device and Documentation Support

### 10.1 Documentation Support

#### 10.1.1 Related Documentation

For related documentation, see the following:

- Texas Instruments, [Implications of Slow or Floating CMOS Inputs](#)

### 10.2 Receiving Notification of Documentation Updates

To receive notification of documentation updates, navigate to the device product folder on [ti.com](#). Click on *Subscribe to updates* to register and receive a weekly digest of any product information that has changed. For change details, review the revision history included in any revised document.

### 10.3 Support Resources

[TI E2E™ support forums](#) are an engineer's go-to source for fast, verified answers and design help — straight from the experts. Search existing answers or ask your own question to get the quick design help you need.

Linked content is provided "AS IS" by the respective contributors. They do not constitute TI specifications and do not necessarily reflect TI's views; see TI's [Terms of Use](#).

### 10.4 Trademarks

TI E2E™ is a trademark of Texas Instruments.  
All trademarks are the property of their respective owners.

### 10.5 Electrostatic Discharge Caution



This integrated circuit can be damaged by ESD. Texas Instruments recommends that all integrated circuits be handled with appropriate precautions. Failure to observe proper handling and installation procedures can cause damage.

ESD damage can range from subtle performance degradation to complete device failure. Precision integrated circuits may be more susceptible to damage because very small parametric changes could cause the device not to meet its published specifications.

### 10.6 Glossary

[TI Glossary](#) This glossary lists and explains terms, acronyms, and definitions.

## 11 Mechanical, Packaging, and Orderable Information

The following pages include mechanical, packaging, and orderable information. This information is the most current data available for the designated devices. This data is subject to change without notice and revision of this document. For browser-based versions of this data sheet, refer to the left-hand navigation.

## PACKAGING INFORMATION

Orderable Device	Status (1)	Package Type	Package Drawing	Package Pins	Package Qty	Eco Plan (2)	Lead finish/ Ball material (6)	MSL Peak Temp (3)	Op Temp (°C)	Device Marking (4/5)	Samples
7901502EA	ACTIVE	CDIP	J	16	1	Non-RoHS & Green	SNPB	N / A for Pkg Type	-55 to 125	7901502EA CD4052BF3A	Samples
8101801EA	ACTIVE	CDIP	J	16	1	Non-RoHS & Green	SNPB	N / A for Pkg Type	-55 to 125	8101801EA CD4053BF3A	Samples
CD4051BE	ACTIVE	PDIP	N	16	25	RoHS & Green	NIPDAU   SN	N / A for Pkg Type	-55 to 125	CD4051BE	Samples
CD4051BEE4	LIFEBUY	PDIP	N	16	25	RoHS & Green	NIPDAU	N / A for Pkg Type	-55 to 125	CD4051BE	
CD4051BF	ACTIVE	CDIP	J	16	1	Non-RoHS & Green	SNPB	N / A for Pkg Type	-55 to 125	CD4051BF	Samples
CD4051BF3A	ACTIVE	CDIP	J	16	1	Non-RoHS & Green	SNPB	N / A for Pkg Type	-55 to 125	CD4051BF3A	Samples
CD4051BM	LIFEBUY	SOIC	D	16	40	RoHS & Green	NIPDAU	Level-1-260C-UNLIM	-55 to 125	CD4051BM	
CD4051BM96	ACTIVE	SOIC	D	16	2500	RoHS & Green	NIPDAU   SN	Level-1-260C-UNLIM	-55 to 125	CD4051BM	Samples
CD4051BM96G3	LIFEBUY	SOIC	D	16	2500	RoHS & Green	SN	Level-1-260C-UNLIM	-55 to 125	CD4051BM	
CD4051BM96G4	LIFEBUY	SOIC	D	16	2500	RoHS & Green	NIPDAU	Level-1-260C-UNLIM	-55 to 125	CD4051BM	
CD4051BMG4	LIFEBUY	SOIC	D	16	40	RoHS & Green	NIPDAU	Level-1-260C-UNLIM	-55 to 125	CD4051BM	
CD4051BMT	LIFEBUY	SOIC	D	16	250	RoHS & Green	NIPDAU	Level-1-260C-UNLIM	-55 to 125	CD4051BM	
CD4051BNSR	ACTIVE	SO	NS	16	2000	RoHS & Green	NIPDAU	Level-1-260C-UNLIM	-55 to 125	CD4051B	Samples
CD4051BPW	LIFEBUY	TSSOP	PW	16	90	RoHS & Green	NIPDAU	Level-1-260C-UNLIM	-55 to 125	CM051B	
CD4051BPWE4	LIFEBUY	TSSOP	PW	16	90	RoHS & Green	NIPDAU	Level-1-260C-UNLIM	-55 to 125	CM051B	
CD4051BPWR	ACTIVE	TSSOP	PW	16	2000	RoHS & Green	NIPDAU   SN	Level-1-260C-UNLIM	-55 to 125	CM051B	Samples
CD4051BPWRG4	LIFEBUY	TSSOP	PW	16	2000	RoHS & Green	NIPDAU	Level-1-260C-UNLIM	-55 to 125	CM051B	
CD4051BQPWRG4KN	LIFEBUY	TSSOP	PW	16	2000	RoHS & Green	NIPDAU	Level-1-260C-UNLIM	-55 to 125	CM051BQ	
CD4052BE	ACTIVE	PDIP	N	16	25	RoHS & Green	NIPDAU   SN	N / A for Pkg Type	-55 to 125	CD4052BE	Samples
CD4052BEE4	ACTIVE	PDIP	N	16	25	RoHS & Non-Green	NIPDAU	N / A for Pkg Type	-55 to 125	CD4052BE	Samples
CD4052BF	ACTIVE	CDIP	J	16	1	Non-RoHS & Green	SNPB	N / A for Pkg Type	-55 to 125	CD4052BF	Samples
CD4052BF3A	ACTIVE	CDIP	J	16	1	Non-RoHS & Green	SNPB	N / A for Pkg Type	-55 to 125	7901502EA CD4052BF3A	Samples

# PACKAGE OPTION ADDENDUM

17-Aug-2023

Orderable Device	Status (1)	Package Type	Package Drawing	Pins	Package Qty	Eco Plan (2)	Lead finish/ Ball material (6)	MSL Peak Temp (3)	Op Temp (°C)	Device Marking (4/5)	Samples
CD4052BM	LIFEBUY	SOIC	D	16	40	RoHS & Green	NIPDAU	Level-1-260C-UNLIM	-55 to 125	CD4052BM	
CD4052BM96	ACTIVE	SOIC	D	16	2500	RoHS & Green	NIPDAU   SN	Level-1-260C-UNLIM	-55 to 125	CD4052BM	Samples
CD4052BM96G3	LIFEBUY	SOIC	D	16	2500	RoHS & Green	SN	Level-1-260C-UNLIM	-55 to 125	CD4052BM	
CD4052BM96G4	LIFEBUY	SOIC	D	16	2500	RoHS & Green	NIPDAU	Level-1-260C-UNLIM	-55 to 125	CD4052BM	
CD4052BMG4	LIFEBUY	SOIC	D	16	40	RoHS & Green	NIPDAU	Level-1-260C-UNLIM	-55 to 125	CD4052BM	
CD4052BMT	LIFEBUY	SOIC	D	16	250	RoHS & Green	NIPDAU	Level-1-260C-UNLIM	-55 to 125	CD4052BM	
CD4052BNS	LIFEBUY	SO	NS	16	50	RoHS & Green	NIPDAU	Level-1-260C-UNLIM	-55 to 125	CD4052B	
CD4052BNSR	ACTIVE	SO	NS	16	2000	RoHS & Green	NIPDAU	Level-1-260C-UNLIM	-55 to 125	CD4052B	Samples
CD4052BPW	LIFEBUY	TSSOP	PW	16	90	RoHS & Green	NIPDAU	Level-1-260C-UNLIM	-55 to 125	CM052B	
CD4052BPWR	ACTIVE	TSSOP	PW	16	2000	RoHS & Green	NIPDAU   SN	Level-1-260C-UNLIM	-55 to 125	CM052B	Samples
CD4052BPWRG3	LIFEBUY	TSSOP	PW	16	2000	RoHS & Green	SN	Level-1-260C-UNLIM	-55 to 125	CM052B	
CD4052BPWRG4	LIFEBUY	TSSOP	PW	16	2000	RoHS & Green	NIPDAU	Level-1-260C-UNLIM	-55 to 125	CM052B	
CD4053BE	ACTIVE	PDIP	N	16	25	RoHS & Green	NIPDAU	N / A for Pkg Type	-55 to 125	CD4053BE	Samples
CD4053BEE4	ACTIVE	PDIP	N	16	25	RoHS & Green	NIPDAU	N / A for Pkg Type	-55 to 125	CD4053BE	Samples
CD4053BF	ACTIVE	CDIP	J	16	1	Non-RoHS & Green	SNPB	N / A for Pkg Type	-55 to 125	CD4053BF	Samples
CD4053BF3A	ACTIVE	CDIP	J	16	1	Non-RoHS & Green	SNPB	N / A for Pkg Type	-55 to 125	8101801EA CD4053BF3A	Samples
CD4053BM	LIFEBUY	SOIC	D	16	40	RoHS & Green	NIPDAU	Level-1-260C-UNLIM	-55 to 125	CD4053M	
CD4053BM96	ACTIVE	SOIC	D	16	2500	RoHS & Green	NIPDAU   SN	Level-1-260C-UNLIM	-55 to 125	CD4053M	Samples
CD4053BM96E4	LIFEBUY	SOIC	D	16	2500	RoHS & Green	NIPDAU	Level-1-260C-UNLIM	-55 to 125	CD4053M	
CD4053BM96G3	LIFEBUY	SOIC	D	16	2500	RoHS & Green	SN	Level-1-260C-UNLIM	-55 to 125	CD4053M	
CD4053BMG4	LIFEBUY	SOIC	D	16	2500	RoHS & Green	NIPDAU	Level-1-260C-UNLIM	-55 to 125	CD4053M	
CD4053BMT	LIFEBUY	SOIC	D	16	40	RoHS & Green	NIPDAU	Level-1-260C-UNLIM	-55 to 125	CD4053M	
CD4053BNSR	ACTIVE	SO	NS	16	2000	RoHS & Green	NIPDAU	Level-1-260C-UNLIM	-55 to 125	CD4053M	Samples
CD4053BPW	LIFEBUY	TSSOP	PW	16	90	RoHS & Green	NIPDAU	Level-1-260C-UNLIM	-55 to 125	CM053B	
CD4053BPWR	ACTIVE	TSSOP	PW	16	2000	RoHS & Green	NIPDAU   SN	Level-1-260C-UNLIM	-55 to 125	CM053B	Samples

Orderable Device	Status (1)	Package Type	Package Drawing	Pins	Package Qty	Eco Plan (2)	Lead finish/ Ball material (6)	MSL Peak Temp (3)	Op Temp (°C)	Device Marking (4/5)	Samples
CD4053BPWRG3	LIFEBUY	TSSOP	PW	16	2000	RoHS & Green	SN	Level-1-260C-UNLIM	-55 to 125	CM053B	
CD4053BPWRG4	LIFEBUY	TSSOP	PW	16	2000	RoHS & Green	NIPDAU	Level-1-260C-UNLIM	-55 to 125	CM053B	

(1) The marketing status values are defined as follows:

**ACTIVE:** Product device recommended for new designs.

**LIFEBUY:** TI has announced that the device will be discontinued, and a lifetime-buy period is in effect.

**NRND:** Not recommended for new designs. Device is in production to support existing customers, but TI does not recommend using this part in a new design.

**PREVIEW:** Device has been announced but is not in production. Samples may or may not be available.

**OBSOLETE:** TI has discontinued the production of the device.

(2) **RoHS:** TI defines "RoHS" to mean semiconductor products that are compliant with the current EU RoHS requirements for all 10 RoHS substances, including the requirement that RoHS substance do not exceed 0.1% by weight in homogeneous materials. Where designed to be soldered at high temperatures, "RoHS" products are suitable for use in specified lead-free processes. TI may reference these types of products as "Pb-Free".

**RoHS Exempt:** TI defines "RoHS Exempt" to mean products that contain lead but are compliant with EU RoHS pursuant to a specific EU RoHS exemption.

**Green:** TI defines "Green" to mean the content of Chlorine (Cl) and Bromine (Br) based flame retardants meet JS709B low halogen requirements of <=1000ppm threshold. Antimony trioxide based flame retardants must also meet the <=1000ppm threshold requirement.

(3) MSL, Peak Temp. - The Moisture Sensitivity Level rating according to the JEDEC industry standard classifications, and peak solder temperature.

(4) There may be additional marking, which relates to the logo, the lot trace code information, or the environmental category on the device.

(5) Multiple Device Markings will be inside parentheses. Only one Device Marking contained in parentheses and separated by a "-" will appear on a device. If a line is indented then it is a continuation of the previous line and the two combined represent the entire Device Marking for that device.

(6) Lead finish/Ball material - Orderable Devices may have multiple material finish options. Finish options are separated by a vertical ruled line. Lead finish/Ball material values may wrap to two lines if the finish value exceeds the maximum column width.

**Important information and Disclaimer:** The information provided on this page represents TI's knowledge and belief as of the date that it is provided. TI bases its knowledge and belief on information provided by third parties, and makes no representation or warranty as to the accuracy of such information. Efforts are underway to better integrate information from third parties. TI has taken and continues to take reasonable steps to provide representative and accurate information but may not have conducted destructive testing or chemical analysis on incoming materials and chemicals. TI and TI suppliers consider certain information to be proprietary, and thus CAS numbers and other limited information may not be available for release.

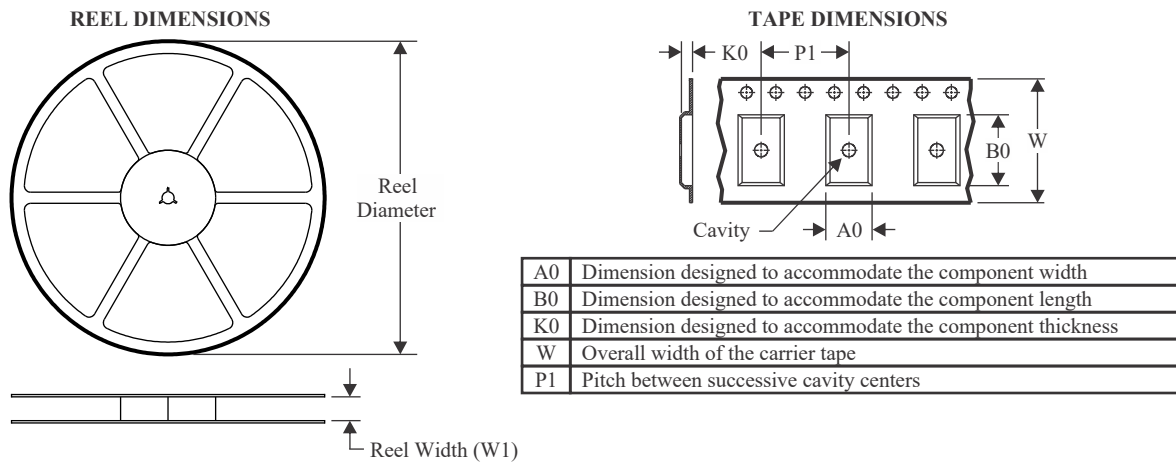
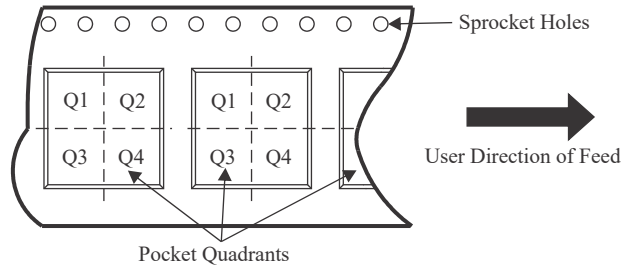
In no event shall TI's liability arising out of such information exceed the total purchase price of the TI part(s) at issue in this document sold by TI to Customer on an annual basis.

**OTHER QUALIFIED VERSIONS OF CD4051B, CD4052B, CD4052B-MIL, CD4053B, CD4053B-MIL :**

- Catalog : CD4051B, CD4052B, CD4053B
- Automotive : CD4051B-Q1, CD4051B-Q1, CD4053B-Q1, CD4053B-Q1
- Military : CD4051B-MIL, CD4052B-MIL, CD4053B-MIL

NOTE: Qualified Version Definitions:

- Catalog - TI's standard catalog product
- Automotive - Q100 devices qualified for high-reliability automotive applications targeting zero defects
- Military - QML certified for Military and Defense Applications

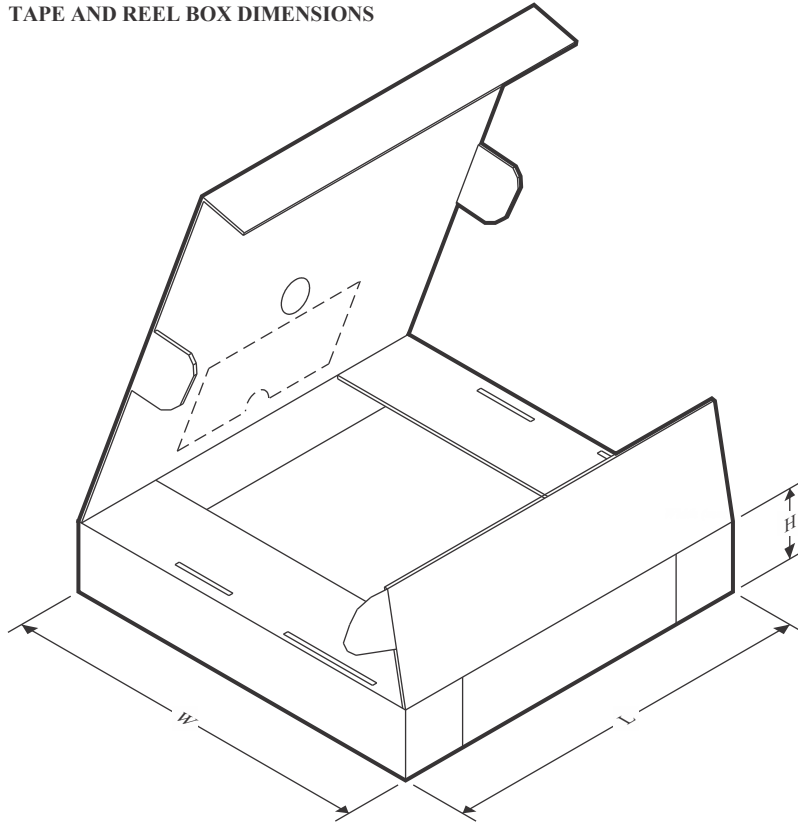
**TAPE AND REEL INFORMATION**

**QUADRANT ASSIGNMENTS FOR PIN 1 ORIENTATION IN TAPE**


\*All dimensions are nominal

Device	Package Type	Package Drawing	Pins	SPQ	Reel Diameter (mm)	Reel Width W1 (mm)	A0 (mm)	B0 (mm)	K0 (mm)	P1 (mm)	W (mm)	Pin1 Quadrant
CD4051BM96	SOIC	D	16	2500	330.0	16.8	6.5	10.3	2.1	8.0	16.0	Q1
CD4051BM96	SOIC	D	16	2500	330.0	16.4	6.5	10.3	2.1	8.0	16.0	Q1
CD4051BM96G3	SOIC	D	16	2500	330.0	16.8	6.5	10.3	2.1	8.0	16.0	Q1
CD4051BM96G4	SOIC	D	16	2500	330.0	16.4	6.5	10.3	2.1	8.0	16.0	Q1
CD4051BNSR	SO	NS	16	2000	330.0	16.4	8.2	10.5	2.5	12.0	16.0	Q1
CD4051BPWR	TSSOP	PW	16	2000	330.0	12.4	6.9	5.6	1.6	8.0	12.0	Q1
CD4051BPWR	TSSOP	PW	16	2000	330.0	12.4	6.9	5.6	1.6	8.0	12.0	Q1
CD4051BPWRG4	TSSOP	PW	16	2000	330.0	12.4	6.9	5.6	1.6	8.0	12.0	Q1
CD4052BM96	SOIC	D	16	2500	330.0	16.8	6.5	10.3	2.1	8.0	16.0	Q1
CD4052BM96	SOIC	D	16	2500	330.0	16.4	6.5	10.3	2.1	8.0	16.0	Q1
CD4052BM96G3	SOIC	D	16	2500	330.0	16.8	6.5	10.3	2.1	8.0	16.0	Q1
CD4052BM96G4	SOIC	D	16	2500	330.0	16.4	6.5	10.3	2.1	8.0	16.0	Q1
CD4052BNSR	SO	NS	16	2000	330.0	16.4	8.2	10.5	2.5	12.0	16.0	Q1
CD4052BPWR	TSSOP	PW	16	2000	330.0	12.4	6.9	5.6	1.6	8.0	12.0	Q1
CD4052BPWR	TSSOP	PW	16	2000	330.0	12.4	6.9	5.6	1.6	8.0	12.0	Q1
CD4052BPWRG3	TSSOP	PW	16	2000	330.0	12.4	6.9	5.6	1.6	8.0	12.0	Q1



Device	Package Type	Package Drawing	Pins	SPQ	Reel Diameter (mm)	Reel Width W1 (mm)	A0 (mm)	B0 (mm)	K0 (mm)	P1 (mm)	W (mm)	Pin1 Quadrant
CD4052BPWRG4	TSSOP	PW	16	2000	330.0	12.4	6.9	5.6	1.6	8.0	12.0	Q1
CD4053BM96	SOIC	D	16	2500	330.0	16.8	6.5	10.3	2.1	8.0	16.0	Q1
CD4053BM96	SOIC	D	16	2500	330.0	16.4	6.5	10.3	2.1	8.0	16.0	Q1
CD4053BM96G3	SOIC	D	16	2500	330.0	16.8	6.5	10.3	2.1	8.0	16.0	Q1
CD4053BM96G4	SOIC	D	16	2500	330.0	16.4	6.5	10.3	2.1	8.0	16.0	Q1
CD4053BNSR	SO	NS	16	2000	330.0	16.4	8.2	10.5	2.5	12.0	16.0	Q1
CD4053BPWR	TSSOP	PW	16	2000	330.0	12.4	6.9	5.6	1.6	8.0	12.0	Q1
CD4053BPWR	TSSOP	PW	16	2000	330.0	12.4	6.9	5.6	1.6	8.0	12.0	Q1
CD4053BPWRG3	TSSOP	PW	16	2000	330.0	12.4	6.9	5.6	1.6	8.0	12.0	Q1
CD4053BPWRG4	TSSOP	PW	16	2000	330.0	12.4	6.9	5.6	1.6	8.0	12.0	Q1

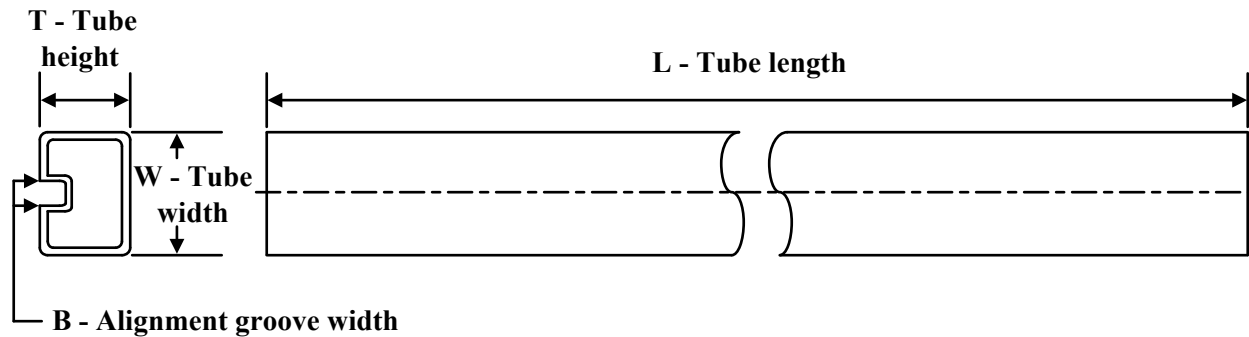
**TAPE AND REEL BOX DIMENSIONS**


\*All dimensions are nominal

Device	Package Type	Package Drawing	Pins	SPQ	Length (mm)	Width (mm)	Height (mm)
CD4051BM96	SOIC	D	16	2500	364.0	364.0	27.0
CD4051BM96	SOIC	D	16	2500	340.5	336.1	32.0
CD4051BM96G3	SOIC	D	16	2500	364.0	364.0	27.0
CD4051BM96G4	SOIC	D	16	2500	340.5	336.1	32.0
CD4051BNSR	SO	NS	16	2000	356.0	356.0	35.0
CD4051BPWR	TSSOP	PW	16	2000	364.0	364.0	27.0
CD4051BPWR	TSSOP	PW	16	2000	367.0	367.0	35.0
CD4051BPWRG4	TSSOP	PW	16	2000	367.0	367.0	35.0
CD4052BM96	SOIC	D	16	2500	364.0	364.0	27.0
CD4052BM96	SOIC	D	16	2500	340.5	336.1	32.0
CD4052BM96G3	SOIC	D	16	2500	364.0	364.0	27.0
CD4052BM96G4	SOIC	D	16	2500	340.5	336.1	32.0
CD4052BNSR	SO	NS	16	2000	356.0	356.0	35.0
CD4052BPWR	TSSOP	PW	16	2000	364.0	364.0	27.0
CD4052BPWR	TSSOP	PW	16	2000	367.0	367.0	35.0
CD4052BPWRG3	TSSOP	PW	16	2000	364.0	364.0	27.0
CD4052BPWRG4	TSSOP	PW	16	2000	367.0	367.0	35.0
CD4053BM96	SOIC	D	16	2500	364.0	364.0	27.0

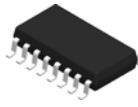
---

<b>Device</b>	<b>Package Type</b>	<b>Package Drawing</b>	<b>Pins</b>	<b>SPQ</b>	<b>Length (mm)</b>	<b>Width (mm)</b>	<b>Height (mm)</b>
CD4053BM96	SOIC	D	16	2500	340.5	336.1	32.0
CD4053BM96G3	SOIC	D	16	2500	364.0	364.0	27.0
CD4053BM96G4	SOIC	D	16	2500	340.5	336.1	32.0
CD4053BNSR	SO	NS	16	2000	356.0	356.0	35.0
CD4053BPWR	TSSOP	PW	16	2000	364.0	364.0	27.0
CD4053BPWR	TSSOP	PW	16	2000	367.0	367.0	35.0
CD4053BPWRG3	TSSOP	PW	16	2000	364.0	364.0	27.0
CD4053BPWRG4	TSSOP	PW	16	2000	367.0	367.0	35.0

**TUBE**


\*All dimensions are nominal

Device	Package Name	Package Type	Pins	SPQ	L (mm)	W (mm)	T (µm)	B (mm)
CD4051BE	N	PDIP	16	25	506	13.97	11230	4.32
CD4051BE	N	PDIP	16	25	506.1	9	600	5.4
CD4051BE	N	PDIP	16	25	506	13.97	11230	4.32
CD4051BEE4	N	PDIP	16	25	506	13.97	11230	4.32
CD4051BEE4	N	PDIP	16	25	506	13.97	11230	4.32
CD4051BM	D	SOIC	16	40	507	8	3940	4.32
CD4051BM	D	SOIC	16	40	506.6	8	3940	4.32
CD4051BMG4	D	SOIC	16	40	506.6	8	3940	4.32
CD4051BMG4	D	SOIC	16	40	507	8	3940	4.32
CD4051BPW	PW	TSSOP	16	90	530	10.2	3600	3.5
CD4051BPWE4	PW	TSSOP	16	90	530	10.2	3600	3.5
CD4052BE	N	PDIP	16	25	506.1	9	600	5.4
CD4052BE	N	PDIP	16	25	506	13.97	11230	4.32
CD4052BE	N	PDIP	16	25	506	13.97	11230	4.32
CD4052BEE4	N	PDIP	16	25	506	13.97	11230	4.32
CD4052BEE4	N	PDIP	16	25	506	13.97	11230	4.32
CD4052BEE4	N	PDIP	16	25	506.1	9	600	5.4
CD4052BM	D	SOIC	16	40	507	8	3940	4.32
CD4052BMG4	D	SOIC	16	40	507	8	3940	4.32
CD4052BNS	NS	SOP	16	50	530	10.5	4000	4.1
CD4052BPW	PW	TSSOP	16	90	530	10.2	3600	3.5
CD4053BE	N	PDIP	16	25	506	13.97	11230	4.32
CD4053BE	N	PDIP	16	25	506	13.97	11230	4.32
CD4053BEE4	N	PDIP	16	25	506	13.97	11230	4.32
CD4053BEE4	N	PDIP	16	25	506	13.97	11230	4.32
CD4053BM	D	SOIC	16	40	507	8	3940	4.32
CD4053BMG4	D	SOIC	16	40	507	8	3940	4.32
CD4053BPW	PW	TSSOP	16	90	530	10.2	3600	3.5

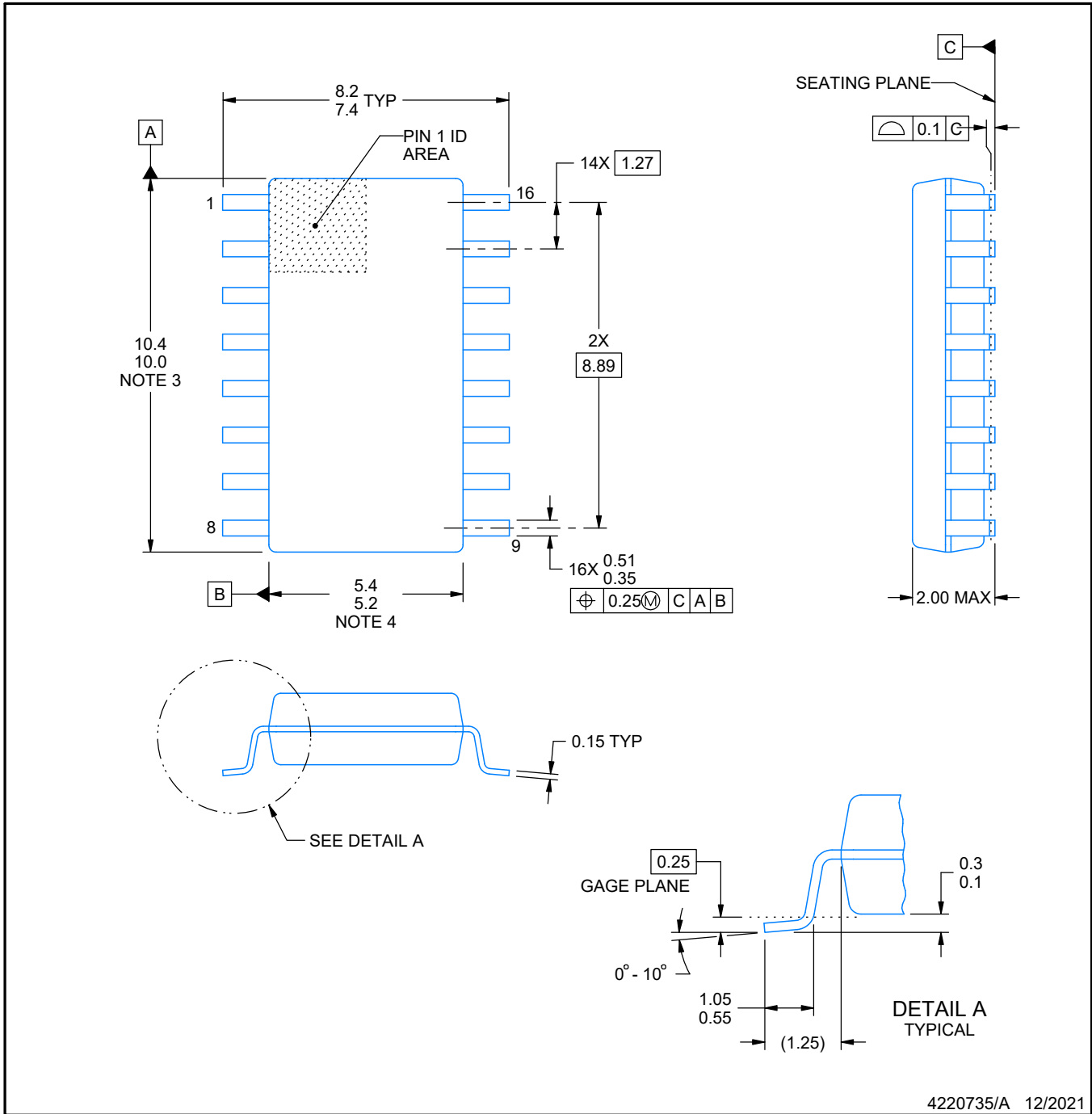


# PACKAGE OUTLINE

## NS0016A

### SOP - 2.00 mm max height

SOP



4220735/A 12/2021

#### NOTES:

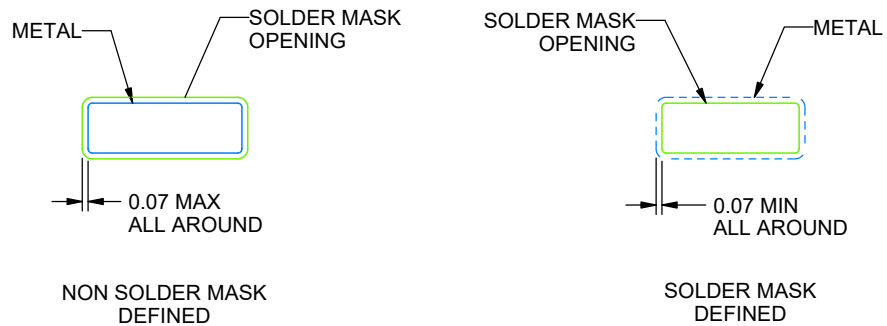
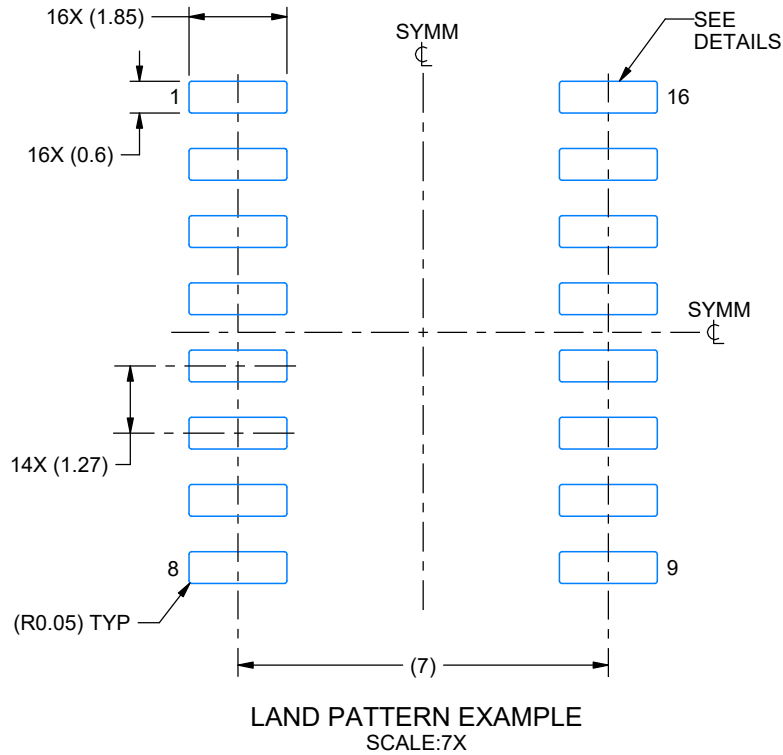
1. All linear dimensions are in millimeters. Dimensions in parenthesis are for reference only. Dimensioning and tolerancing per ASME Y14.5M.
2. This drawing is subject to change without notice.
3. This dimension does not include mold flash, protrusions, or gate burrs. Mold flash, protrusions, or gate burrs shall not exceed 0.15 mm, per side.
4. This dimension does not include interlead flash. Interlead flash shall not exceed 0.25 mm, per side.

# EXAMPLE BOARD LAYOUT

NS0016A

SOP - 2.00 mm max height

SOP



4220735/A 12/2021

NOTES: (continued)

5. Publication IPC-7351 may have alternate designs.

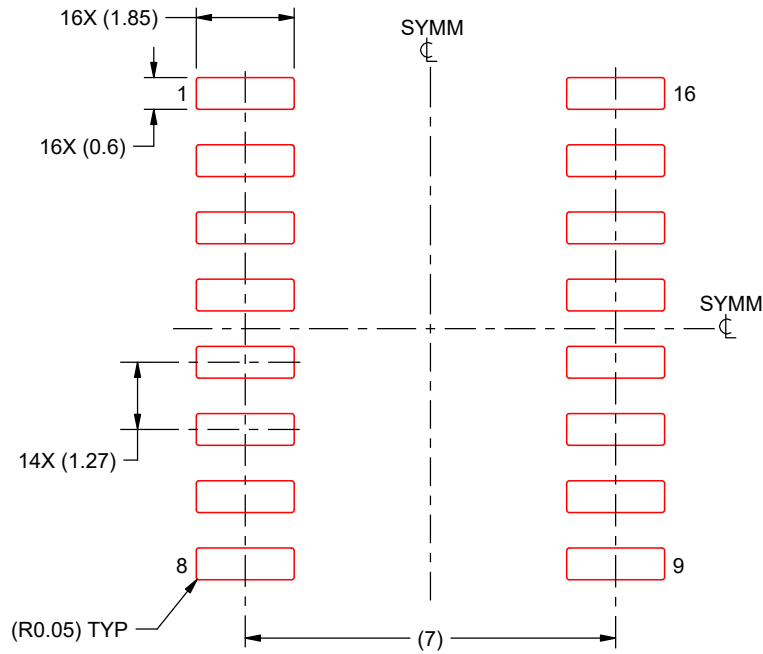
6. Solder mask tolerances between and around signal pads can vary based on board fabrication site.

# EXAMPLE STENCIL DESIGN

NS0016A

SOP - 2.00 mm max height

SOP



SOLDER PASTE EXAMPLE  
BASED ON 0.125 mm THICK STENCIL  
SCALE:7X

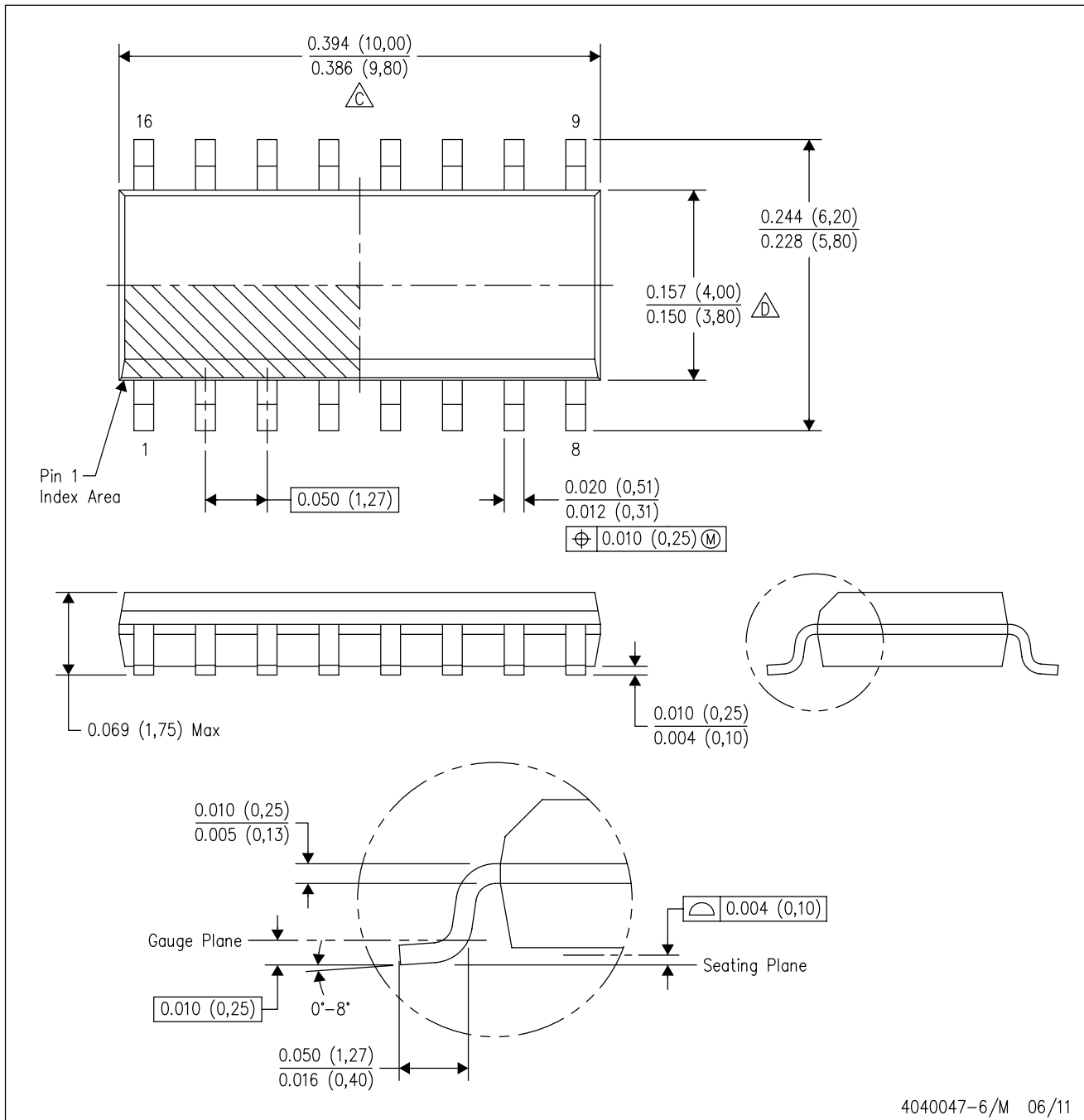
4220735/A 12/2021

NOTES: (continued)

7. Laser cutting apertures with trapezoidal walls and rounded corners may offer better paste release. IPC-7525 may have alternate design recommendations.
8. Board assembly site may have different recommendations for stencil design.

D (R-PDSO-G16)

PLASTIC SMALL OUTLINE

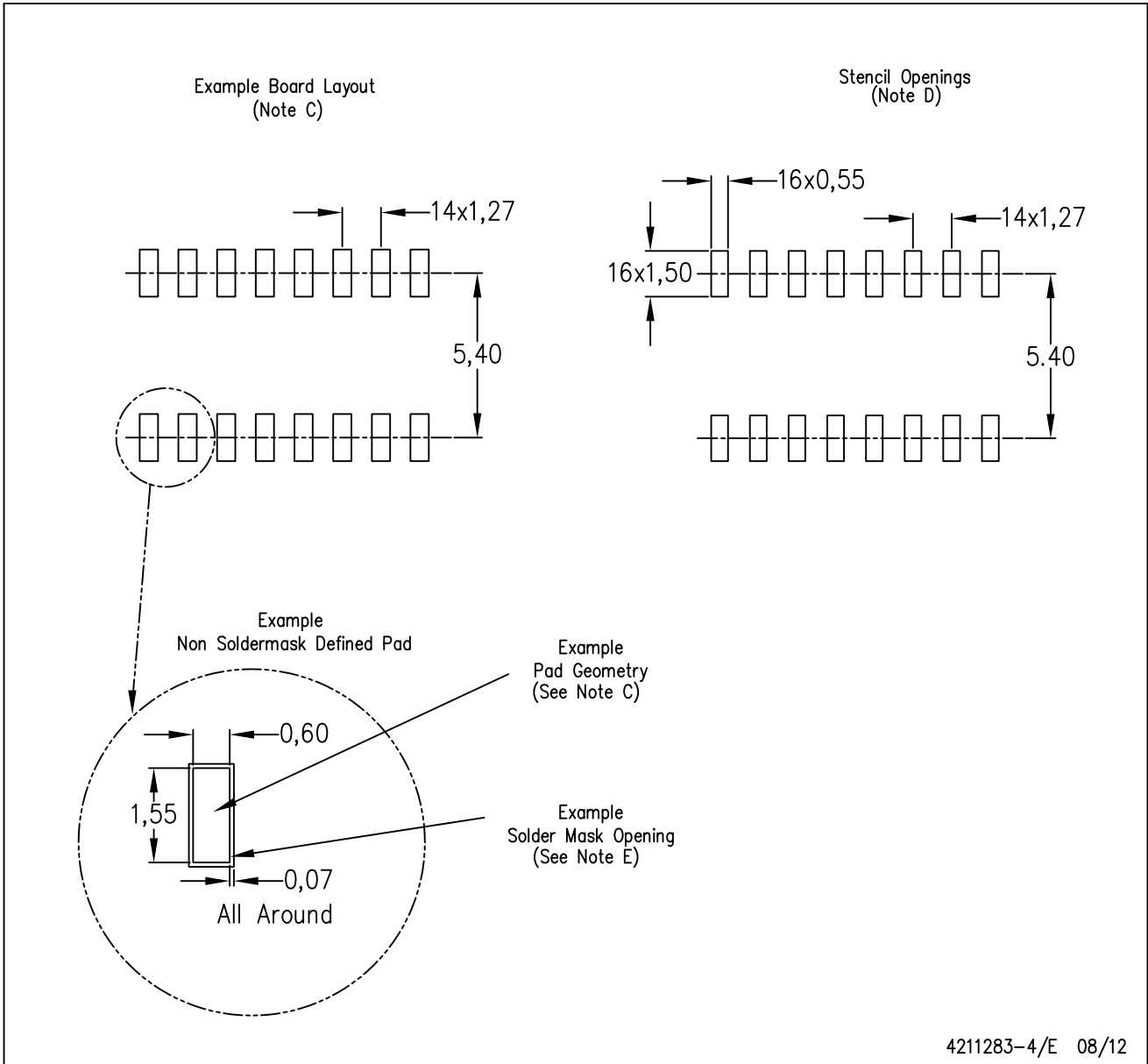


- NOTES:
- A. All linear dimensions are in inches (millimeters).
  - B. This drawing is subject to change without notice.
  - C. Body length does not include mold flash, protrusions, or gate burrs. Mold flash, protrusions, or gate burrs shall not exceed 0.006 (0,15) each side.
  - D. Body width does not include interlead flash. Interlead flash shall not exceed 0.017 (0,43) each side.
  - E. Reference JEDEC MS-012 variation AC.

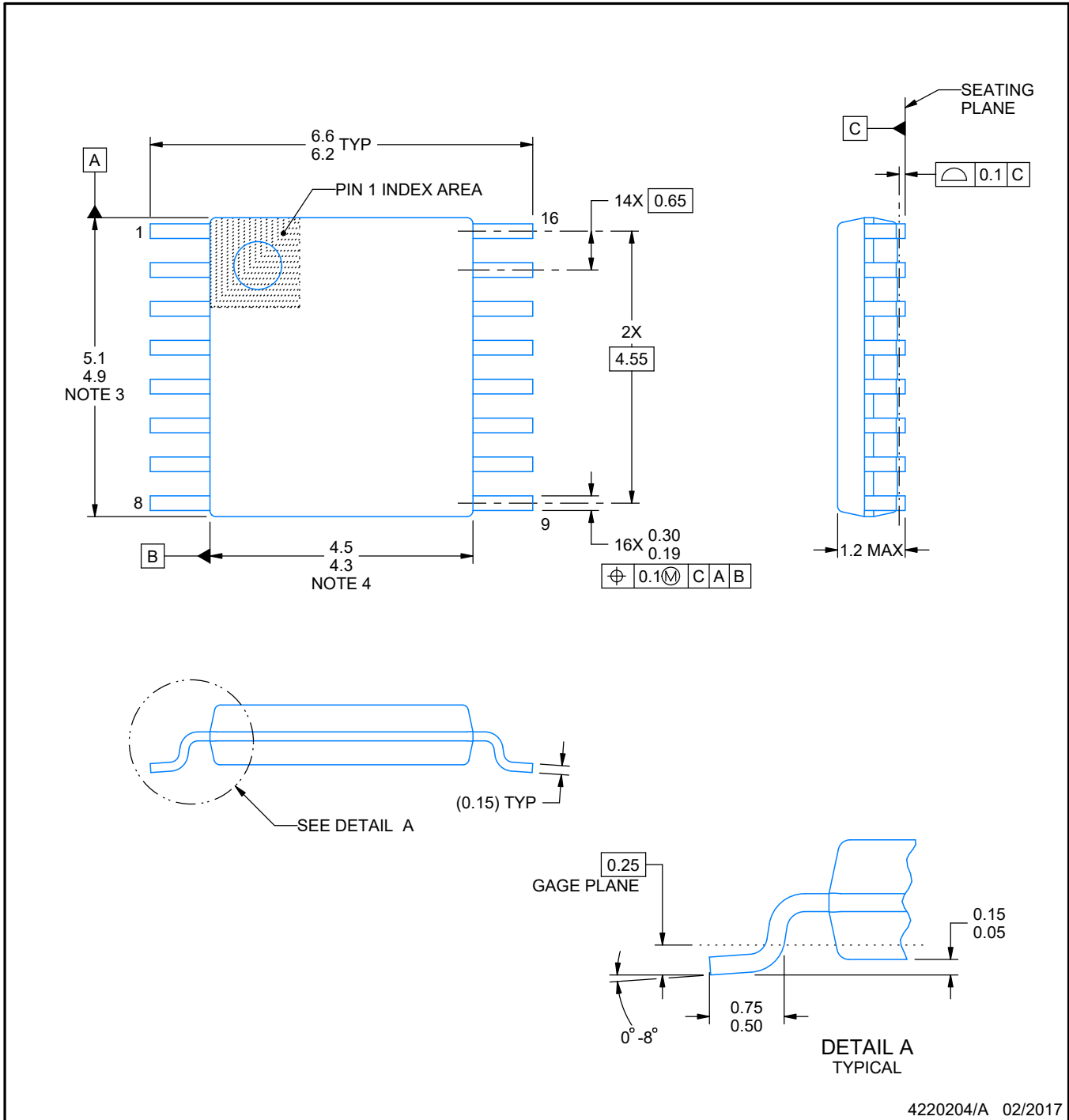
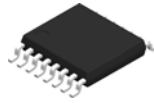


D (R-PDSO-G16)

PLASTIC SMALL OUTLINE



- NOTES:
- A. All linear dimensions are in millimeters.
  - B. This drawing is subject to change without notice.
  - C. Publication IPC-7351 is recommended for alternate designs.
  - D. Laser cutting apertures with trapezoidal walls and also rounding corners will offer better paste release. Customers should contact their board assembly site for stencil design recommendations. Refer to IPC-7525 for other stencil recommendations.
  - E. Customers should contact their board fabrication site for solder mask tolerances between and around signal pads.



4220204/A 02/2017

NOTES:

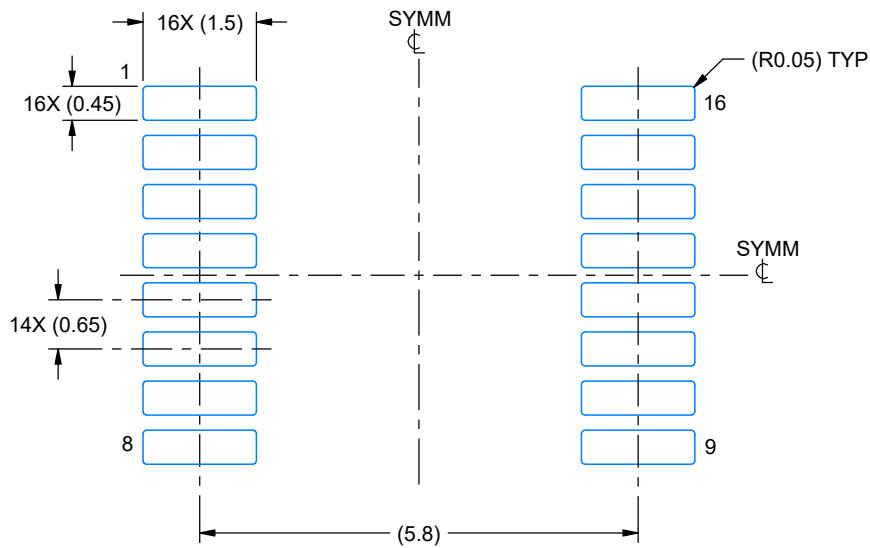
1. All linear dimensions are in millimeters. Any dimensions in parenthesis are for reference only. Dimensioning and tolerancing per ASME Y14.5M.
2. This drawing is subject to change without notice.
3. This dimension does not include mold flash, protrusions, or gate burrs. Mold flash, protrusions, or gate burrs shall not exceed 0.15 mm per side.
4. This dimension does not include interlead flash. Interlead flash shall not exceed 0.25 mm per side.
5. Reference JEDEC registration MO-153.

# EXAMPLE BOARD LAYOUT

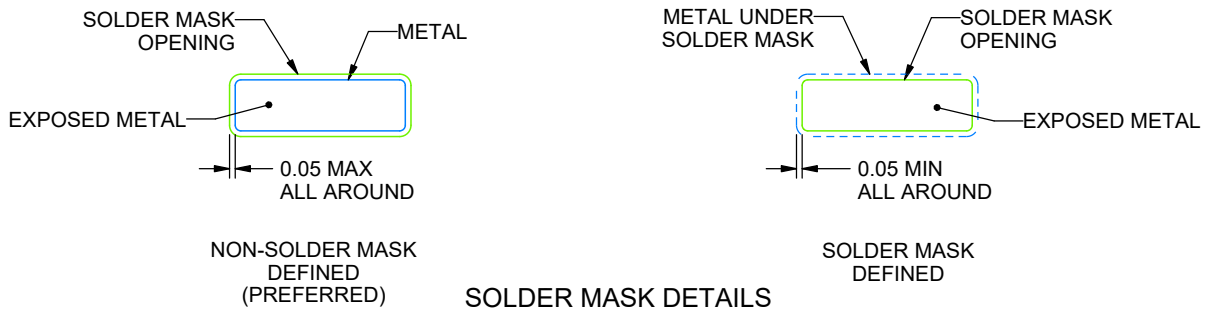
PW0016A

TSSOP - 1.2 mm max height

SMALL OUTLINE PACKAGE



LAND PATTERN EXAMPLE  
EXPOSED METAL SHOWN  
SCALE: 10X



SOLDER MASK DETAILS

4220204/A 02/2017

NOTES: (continued)

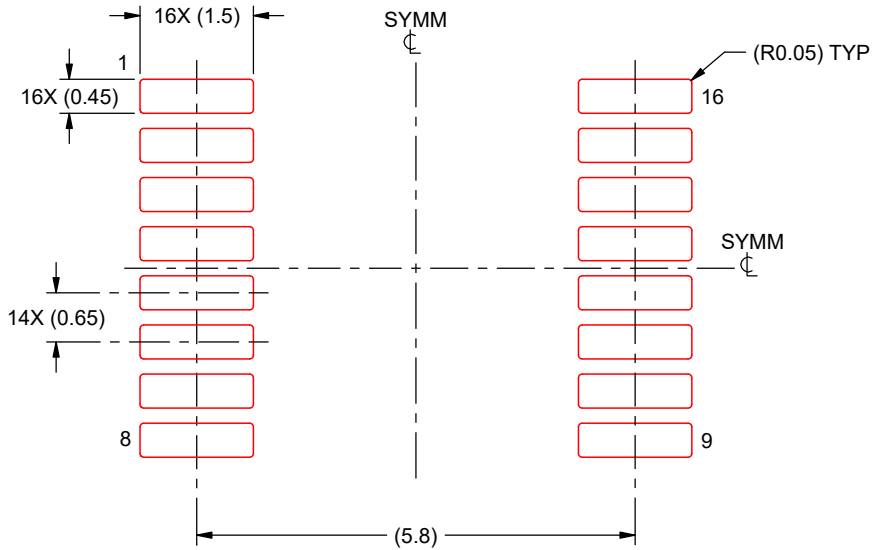
6. Publication IPC-7351 may have alternate designs.
7. Solder mask tolerances between and around signal pads can vary based on board fabrication site.

# EXAMPLE STENCIL DESIGN

PW0016A

TSSOP - 1.2 mm max height

SMALL OUTLINE PACKAGE



SOLDER PASTE EXAMPLE  
BASED ON 0.125 mm THICK STENCIL  
SCALE: 10X

4220204/A 02/2017

NOTES: (continued)

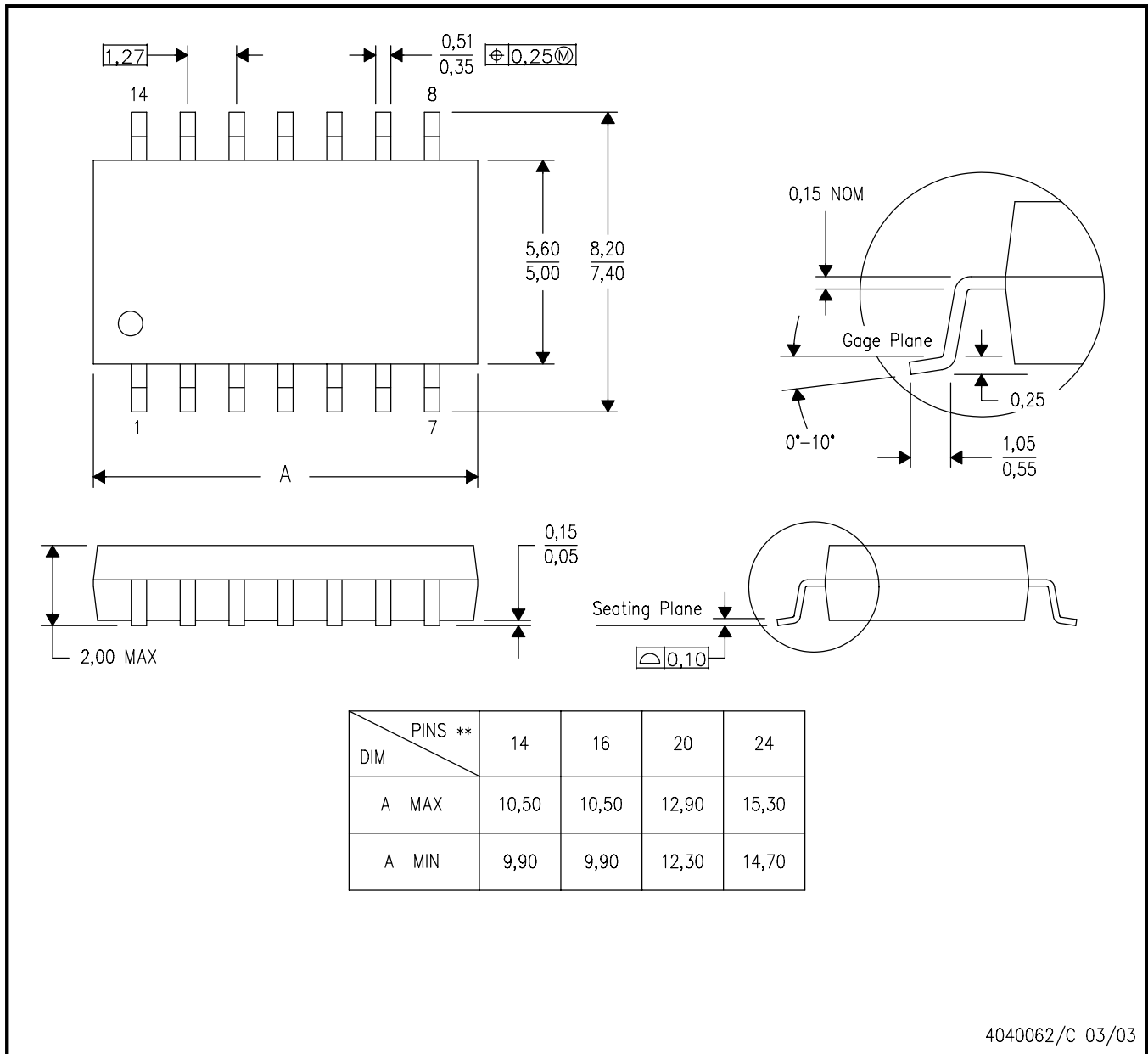
8. Laser cutting apertures with trapezoidal walls and rounded corners may offer better paste release. IPC-7525 may have alternate design recommendations.
9. Board assembly site may have different recommendations for stencil design.

# MECHANICAL DATA

NS (R-PDSO-G\*\*)

PLASTIC SMALL-OUTLINE PACKAGE

14-PINS SHOWN

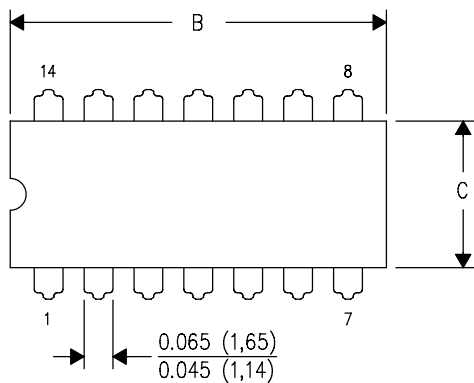


- NOTES:
- A. All linear dimensions are in millimeters.
  - B. This drawing is subject to change without notice.
  - C. Body dimensions do not include mold flash or protrusion, not to exceed 0,15.

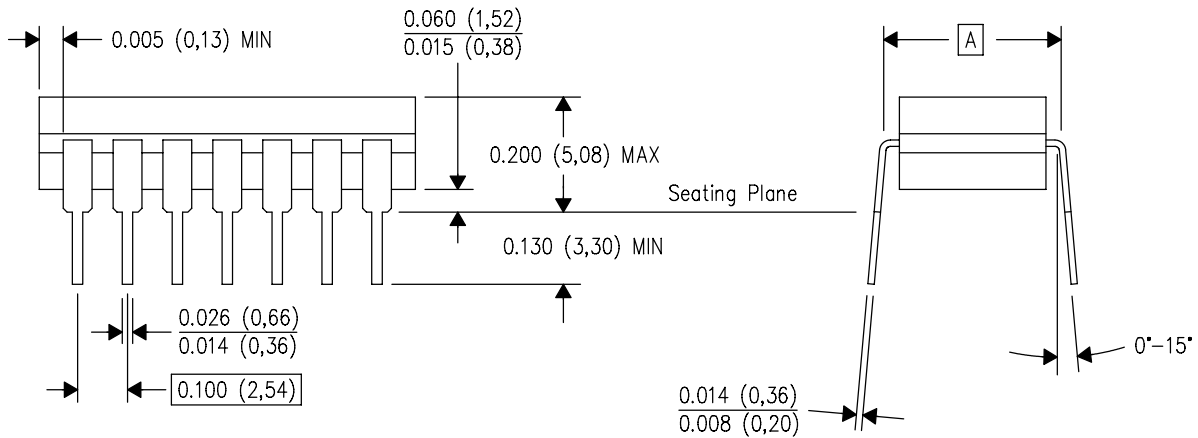
J (R-GDIP-T\*\*)

14 LEADS SHOWN

CERAMIC DUAL IN-LINE PACKAGE



DIM \ PINS **	14	16	18	20
A	0.300 (7,62) BSC	0.300 (7,62) BSC	0.300 (7,62) BSC	0.300 (7,62) BSC
B MAX	0.785 (19,94)	.840 (21,34)	0.960 (24,38)	1.060 (26,92)
B MIN	—	—	—	—
C MAX	0.300 (7,62)	0.300 (7,62)	0.310 (7,87)	0.300 (7,62)
C MIN	0.245 (6,22)	0.245 (6,22)	0.220 (5,59)	0.245 (6,22)



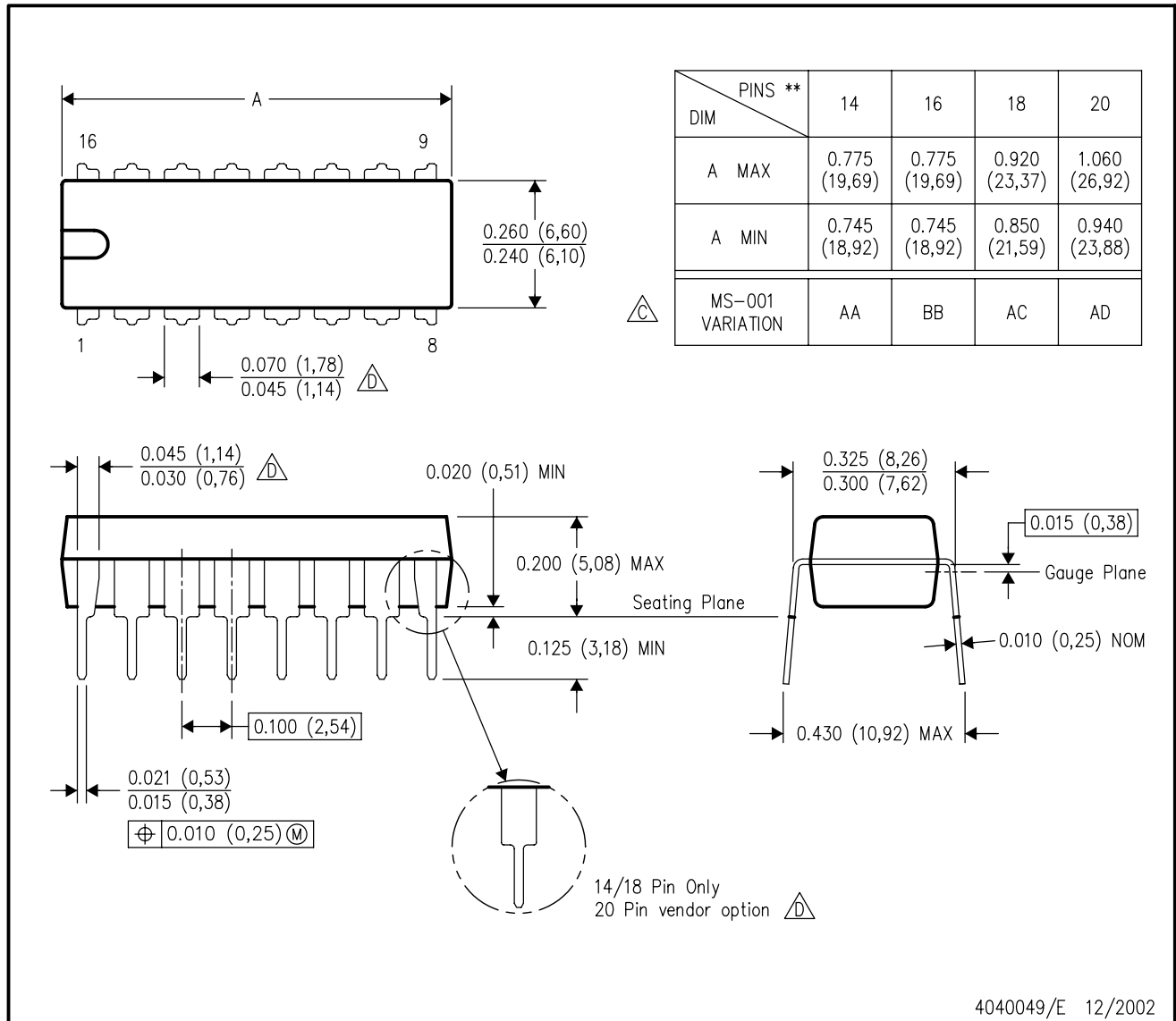
4040083/F 03/03

- NOTES:
- All linear dimensions are in inches (millimeters).
  - This drawing is subject to change without notice.
  - This package is hermetically sealed with a ceramic lid using glass frit.
  - Index point is provided on cap for terminal identification only on press ceramic glass frit seal only.
  - Falls within MIL STD 1835 GDIP1-T14, GDIP1-T16, GDIP1-T18 and GDIP1-T20.

N (R-PDIP-T\*\*)

PLASTIC DUAL-IN-LINE PACKAGE

16 PINS SHOWN



- NOTES:
- A. All linear dimensions are in inches (millimeters).
  - B. This drawing is subject to change without notice.
  - Falls within JEDEC MS-001, except 18 and 20 pin minimum body length (Dim A).
  - The 20 pin end lead shoulder width is a vendor option, either half or full width.

## IMPORTANT NOTICE AND DISCLAIMER

TI PROVIDES TECHNICAL AND RELIABILITY DATA (INCLUDING DATA SHEETS), DESIGN RESOURCES (INCLUDING REFERENCE DESIGNS), APPLICATION OR OTHER DESIGN ADVICE, WEB TOOLS, SAFETY INFORMATION, AND OTHER RESOURCES "AS IS" AND WITH ALL FAULTS, AND DISCLAIMS ALL WARRANTIES, EXPRESS AND IMPLIED, INCLUDING WITHOUT LIMITATION ANY IMPLIED WARRANTIES OF MERCHANTABILITY, FITNESS FOR A PARTICULAR PURPOSE OR NON-INFRINGEMENT OF THIRD PARTY INTELLECTUAL PROPERTY RIGHTS.

These resources are intended for skilled developers designing with TI products. You are solely responsible for (1) selecting the appropriate TI products for your application, (2) designing, validating and testing your application, and (3) ensuring your application meets applicable standards, and any other safety, security, regulatory or other requirements.

These resources are subject to change without notice. TI grants you permission to use these resources only for development of an application that uses the TI products described in the resource. Other reproduction and display of these resources is prohibited. No license is granted to any other TI intellectual property right or to any third party intellectual property right. TI disclaims responsibility for, and you will fully indemnify TI and its representatives against, any claims, damages, costs, losses, and liabilities arising out of your use of these resources.

TI's products are provided subject to [TI's Terms of Sale](#) or other applicable terms available either on [ti.com](#) or provided in conjunction with such TI products. TI's provision of these resources does not expand or otherwise alter TI's applicable warranties or warranty disclaimers for TI products.

TI objects to and rejects any additional or different terms you may have proposed.

Mailing Address: Texas Instruments, Post Office Box 655303, Dallas, Texas 75265  
Copyright © 2023, Texas Instruments Incorporated